

Recursive Least Squares Method in Parameters Identification of DC Motors Models

Dedicated to Professor Milić Stojić on the occasion of his 65th birthday

Radojka Krneta, Sanja Antić, and Danilo Stojanović

Abstract: The procedure of parameters identification of DC motor model using a method of recursive least squares is described in this paper. To identify the system an experimental measuring of signals was carrying out at input - supply of voltage and output of the system for identification - motor angle speed. For the needs of the experiment, a system has been configured with a motor and an optical encoder whose output is connected with the counter input of acquisition card LCK-6013 which over a block connector CB-68LP makes a connection with a computer. The speed of the motor measured by optical encoder is compared with the speed of identified system in order to confirm the quality of the motor model's parameters estimation.

Keywords: DC motor, motor speed, optical coder, servo-mechanism, RLS algorithm, parameter identification.

1 Introduction

For the real velocity servo-mechanism consisting of DC motor and optical encoder, which is used to measure speed on the motor axle, a mathematical model of DC motor has been accepted expressed by this equation (1) [1]:

$$G(s) = \frac{\Omega(s)}{U_r(s)} = \frac{K_m}{sT_m + 1}, \quad (1)$$

where $\Omega(s)$ is motor angle speed, $U_r(s)$ is voltage on the rotor windings of a DC motor, K_m is gain factor and T_m is mechanical time constant. Parameters K_m and

Manuscript received September 3, 2005.

The authors are with Technical faculty of Čačak, Svetog Save 65, 32000 Čačak, Serbia and Montenegro (e-mail: radojka@tfc.kg.ac.yu).

T_m are unknown and their values should be identified in order to analyze the behavior of the system whose mathematical model is given by the relation (1). For the identification of parameters of the observed DC motor, a method of Recursive Least Squares -RLS is going to be used.

In Fig.1.there is a structure of velocity servo-mechanism consisting of DC motor, of unknown parameters and optical encoder which can be used for detecting speed and angle position on the motor axle.

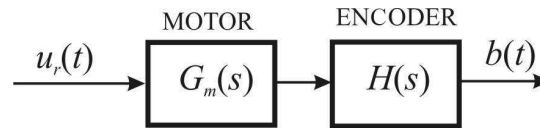

Fig. 1. Structure of velocity servo-mechanism consisting of DC motor and optical encoder.

DC voltage $u_4(t) = 7 \text{ V}$ is brought to the input of the motor over potentiometer, and optical encoder of incremental type which is fed by direct voltage $u_r(t) = 12 \text{ V}$ over rectifier, is used to detect the speed. In Fig.2 a scheme of the link between a DC motor and the optical encoder is shown.

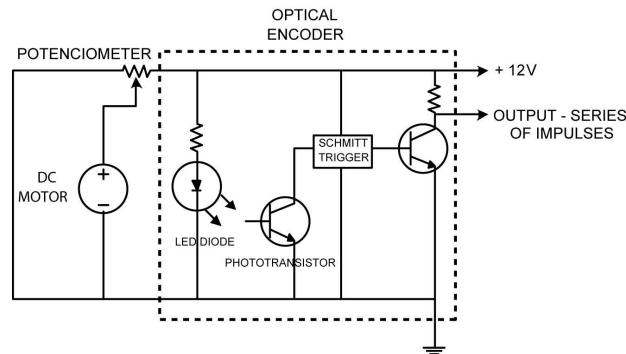

Fig. 2. Scheme of the link between a DC motor and the optical encoder.

The optical encoder has three main elements: rotating disk with 55 transparent and opaque segments, a light source - LED diode and light detector -phototransistor. The source of light - LED diode (Light Emitting Diode) gives a thin infrared beam of powerful intensity which is either passed through or blocked by the rotating disk. This beam is detected by the phototransistor and it activates Schmitt's trigger which enables obtaining a rectangle series of impulses at the output.

The series of impulses from optical encoder over block connector CB-68LP is brought to the counter input of acquisition card NI PCI-6013. By applying the program packet LABVIEW a sequence is formed which contains the number of

impulses in the selected sampling moments $b(t)$ - which represents samples of the motor shaft speed. (Fig.1). Such a procedure of detection of speed is not the best. At lower speeds the accuracy of detection decreases, while read samples do not represent real speed samples, but mean value of speed between the two successive moments of sampling. Nevertheless, at nominal speeds and relatively short periods of sampling the procedure gives good results and it is applied because of its simplicity [1]. Further identification is carried out by application of RLS algorithm which has been realized by using a program packet MATLAB.

2 Recursive least squares method

Let the system model is given in the form

$$Ay(t) = Bu(t - 1), \quad (2)$$

where $u(t)$ is discrete input signal, $y(t)$ is discrete output signal, and

$$A(z^{-1}) = 1 + a_1z^{-1} + a_2z^{-2} + \dots + a_{n_a}z^{-n_a} \quad (3)$$

$$B(z^{-1}) = B_0 + b_1z^{-1} + b_2z^{-2} + \dots + b_{n_b}z^{-n_b} \quad (4)$$

A model of the system (2) can be presented in the form of

$$y(t) = \mathbf{x}^T \boldsymbol{\theta} \quad (5)$$

where $\boldsymbol{\theta}$ is a vector of unknown parameters defined by

$$\boldsymbol{\theta}^T = [-a_1, \dots, -a_{n_a}, b_0, \dots, b_{n_b}] \quad (6)$$

and $\boldsymbol{\theta}$, vector of regression which consists of measured values of input and output

$$\mathbf{x}^T(t) = [y(t-1), \dots, y(t-n_a), u(t-1), \dots, u(t-n_b-1)] \quad (7)$$

A model given with (5) presents an accurate description of the system. However, in this expression the vector of system parameters $\boldsymbol{\theta}$ is not known. It is important to determine it by using available data in signal samples at system output and input. For that purpose a model of a system is supposed

$$y(t) = \mathbf{x}^T(t) \hat{\boldsymbol{\theta}} + \hat{e}(t) \quad (8)$$

where $\hat{\boldsymbol{\theta}}$ is a vector of supposed values of system parameters, and $\hat{e}(t)$ is an error in modeling at the moment t .

The vector of supposed values of the parameters, $\hat{\boldsymbol{\theta}}$, should be chosen in such a way that the whole error in modeling can be minimized. From (5) and (8) it appears that

$$\hat{\varepsilon}(t) = \mathbf{x}^T(\boldsymbol{\theta} - \hat{\boldsymbol{\theta}}) \quad (9)$$

After the time interval of N sampling periods, a model (8) can be shown in a vector form

$$\begin{bmatrix} y(1) \\ y(2) \\ \vdots \\ y(N) \end{bmatrix} = \begin{bmatrix} \mathbf{x}^T(1) \\ \mathbf{x}^T(2) \\ \vdots \\ \mathbf{x}^T(N) \end{bmatrix} \hat{\boldsymbol{\theta}} + \begin{bmatrix} \hat{\varepsilon}(1) \\ \hat{\varepsilon}(2) \\ \vdots \\ \hat{\varepsilon}(N) \end{bmatrix} \quad (10)$$

To have a uniform solution to equation (10) according to estimated parameters, the following parameters should be like this $N = m$, where m is a number of parameters which is estimated, that is $m = n_a + n_b + 1$. For solving equation (10), in practice, Linear Least Squares Algorithm is often used.

Linear Least Squares Algorithm means that $\hat{\boldsymbol{\theta}}$ is chosen in such a way to minimize a sum of square errors [2]

$$J = \sum_{t=1}^N \hat{\varepsilon}^2 = \hat{\boldsymbol{\varepsilon}}^T \hat{\boldsymbol{\varepsilon}} \quad (11)$$

To conclude, vector of the supposed parameters of the system, $\hat{\boldsymbol{\theta}}$, presents the solution to the equation

$$\frac{\partial J}{\partial \hat{\boldsymbol{\theta}}} = 0 \quad (12)$$

According to (10) and (11), the solution of the equation (12) has a form

$$\hat{\boldsymbol{\theta}} = [\mathbf{X}^T \mathbf{X}]^{-1} [\mathbf{X}^T \mathbf{y}] \quad (13)$$

Sometimes, the assessment is needed to be done whenever the information is coming about input/output samples, that is, in each sampling period. The technique which is appropriate for this purpose is Recursive Least Squares Method. With this method, a supposed model from the previous sampling period $\hat{\boldsymbol{\theta}}(t-1)$ is used for assessment of $\hat{y}(t)$ - system output in the given sampling period. Estimated system output is compared with the real system output $y(t)$ and on the basis of the obtained difference an error signal $\varepsilon(t)$ is generated. Now, so called mechanism of updating, on the basis of error signal, correct values of supposed parameters of the system $\hat{\boldsymbol{\theta}}(t-1)$ on $\hat{\boldsymbol{\theta}}(t)$. Scheme of the recursive estimation is given in Fig.3.

If the following symbols are introduced

$$\mathbf{P}(t) = [\mathbf{X}^T(t) \mathbf{X}(t)]^{-1} \quad (14)$$

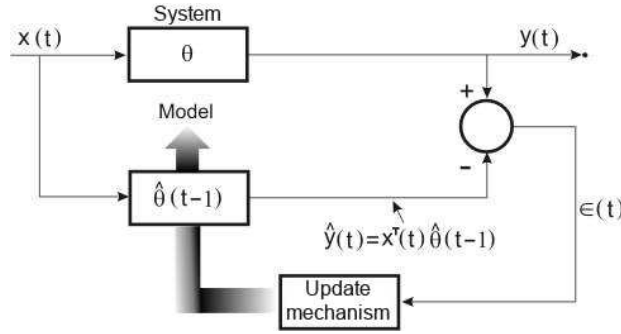

Fig. 3. Scheme of Recursive Least Squares Method.

where $\mathbf{P}(t)$ presents so called covariant matrix and

$$\mathbf{B}(t) = \mathbf{X}^T(t)\mathbf{y}(t) \quad (15)$$

by using ‘Matrix Inversion Lemma’ [2]

$$(\mathbf{A} + \mathbf{BCD})^{-1} = \mathbf{A}^{-1} - \mathbf{A}^{-1}\mathbf{B}(\mathbf{C}^{-1} + \mathbf{DA}^{-1}\mathbf{B})^{-1}\mathbf{DA}^{-1}, \quad (16)$$

and by introducing the following symbols

$$\mathbf{A} = \mathbf{P}^{-1}(t), \quad \mathbf{C} = 1, \quad \mathbf{B} = \mathbf{x}(t+1), \quad \mathbf{D} = \mathbf{x}^T(t+1), \quad (17)$$

we get

$$\mathbf{P}(t+1) = \mathbf{P}(t) \left[\mathbf{I}_m - \frac{\mathbf{x}(t+1)\mathbf{x}^T(t+1)\mathbf{P}(t)}{1 + \mathbf{x}^T(t+1)\mathbf{P}(t)\mathbf{x}(t+1)} \right] \quad (18)$$

From Fig.3. it can be seen that

$$\varepsilon(t+1) = y(t+1) - \mathbf{x}^T(t+1)\hat{\boldsymbol{\theta}}(t) \quad (19)$$

After simple mathematical transformations a vector of assessed unknown parameters is obtained in the form of [2]

$$\hat{\boldsymbol{\theta}}(t+1) = \hat{\boldsymbol{\theta}}(t) + \mathbf{P}(t+1)\mathbf{x}(t+1)\varepsilon(t+1). \quad (20)$$

Application of Recursive Least Squares Method demands supposition of starting values of system parameters $\hat{\boldsymbol{\theta}}(0)$ and covariance matrix, $\mathbf{p}(0)$.

To choose the starting system parameters there are several solutions:

- i) Existence of previous knowledge about the system like the possibility of placing suitable mathematical model which suggest the choice of starting system parameters.

- ii) The technique which is useful when there is no other primary information about the system is using a supposition that the system is integrator of the first order with unit gain [2]. In this way the starting values of the system parameters should be chosen in the form of

$$a_1 = -1, \quad b_0 = T, \quad a_i = 0 \quad (i \neq 1), \quad b_i = 0 \quad (i \neq 1). \quad (21)$$

Generally looking, the choice of the starting values of the system parameters is not crucial for achieving stationary values of the system parameters, but is important for their convergence. Still, error in estimation of parameters depends on these accepted values.

The choice of the starting value of covariance matrix, $\mathbf{P}(t)$, also presents an important step when applying RLS algorithm. If there is no primary knowledge about the system, that is, the system parameters, the choice of great starting value of covariance matrix $\mathbf{P}(0)$ is recommended [2]. However, if the starting values similar to exact values of the system parameters can be accepted, then it is enough to choose the little starting value of the covariance matrix.

In order to show the influence of the starting value of covariance matrix on the covariance matrix itself the following expression can be looked at

$$\mathbf{P}(t) = \left[\mathbf{P}^{-1}(0) + \sum_{i=1}^t \mathbf{x}(i)\mathbf{x}^T(i) \right]^{-1}. \quad (22)$$

It can be seen from (22) that the choice of great value $\mathbf{P}(0)$ much less influences on $\mathbf{P}(t)$ than the data value $\mathbf{x}(i)$. Vice versa, $\mathbf{P}(0)$ if has little value its influence is much greater.

A standard choice of the matrix $\mathbf{P}(0)$ can be presented in the form

$$\mathbf{P}(0) = r\mathbf{I}_m, \quad (23)$$

where \mathbf{I}_m is a unit matrix of the order m , and m is total number of the system parameters.

It is usually chosen $r = 100 - 10000$ for the big value of covariance matrix $\mathbf{P}(0)$, while for the little starting value of covariance matrix, $\mathbf{P}(0)$, understands $r = 1-10$.

3 Identification of DC motor parameters by applying RLS algorithm

Variable $b(t)$ represents a signal at speed servo-system output from the Fig. 1 and it can be expressed as a number of impulses in the time interval

$$b(t) = \frac{K_n}{2\pi} [\Theta(t) - \Theta(t - T)] \quad (24)$$

where $\Theta(t)$ is an angle position expressed in radians, K_n is a number of openings on a disc, and T is a chosen interval of sampling.

Laplace transformation of relation (24) is

$$B(s) = \frac{K_n}{2\pi} \frac{1 - e^{-Ts}}{s} \Omega(s). \quad (25)$$

Here it comes out that the transfer function of optical encoder is

$$H(s) = \frac{B(s)}{\Omega(s)} = \frac{K_n}{2\pi} \frac{1 - e^{-Ts}}{s}. \quad (26)$$

If we consider motor and optical encoder in a general sense as a control object, and its transfer function on the basis of (1) and (25) is in the form of

$$G(s) = \frac{B(s)}{U_r(s)} = \frac{K(1 - e^{-Ts})}{s(T_m s + 1)} \quad (27)$$

where

$$K = K_m \frac{K_n}{2\pi} \quad (28)$$

System for identification of motor parameters is a digital system whose structure is like in Fig.4.

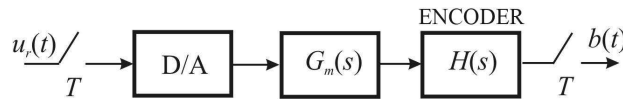

Fig. 4. Structure of speed servo-mechanism with a DC motor, optical encoder and D/A converter.

For D/A conversion a sample hold circuit of zero order is used whose transfer function is

$$G_h(s) = \frac{1 - e^{-Ts}}{s} \quad (29)$$

Thus the system for identification from Fig.4. can be described by transfer function in the form of

$$\begin{aligned} G_p(z) &= \mathcal{Z}\{G_h(s)G_p(s)\} = (1 - z^{-1}) \mathcal{Z}\left\{\frac{K(1 - e^{-Ts})}{s^2(T_m s + 1)}\right\} \\ &= (1 - z^{-1})^2 \mathcal{Z}\left\{\frac{K}{s^2(T_m s + 1)}\right\} = \frac{b_0 z^{-1} + B_1 z^{-2}}{a_0 + a_1 z^{-1}} \end{aligned} \quad (30)$$

where T is a sampling period,

$$\begin{aligned} b_0 &= K[T - T_m(1 - e^{-\frac{T}{T_m}})], & a_0 &= 1, \\ b_1 &= K[-Te^{-\frac{T}{T_m}} + T_m(1 - e^{-\frac{T}{T_m}})], & a_1 &= -e^{-\frac{T}{T_m}}. \end{aligned} \quad (31)$$

By using a program packet LABVIEW samples of variable $b(t)$ have been recorded which together with samples of input DC voltage on the rotor of DC motor - $u_r(t)$, form a vector of input and output, respectively. Block diagram of LABVIEW program for getting speed samples is shown in Fig. 5.

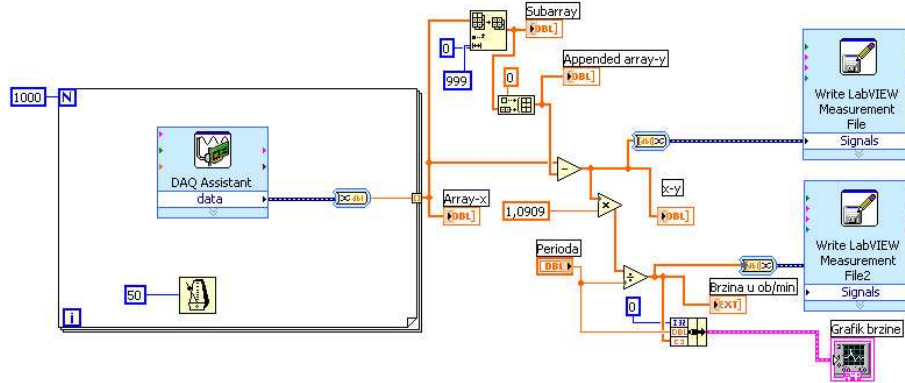

Fig. 5. Block diagram of LABVIEW program for getting speed samples in the given interval of sampling.

RLS algorithm for identification of DC motor parameters is realized in MATLAB.

For the sampling period $t = 0.05s$, when the motor feed voltage $u_r(t) = 7V$ the following results of recording of input and output samples have been obtained during 50s - Fig.6.

$$a_1 \simeq -0.4936 \quad b_0 \simeq 0.1429 \quad b_1 \simeq 3.2857 \quad (32)$$

Accordingly, transfer function of the observed system, on the basis of (30) and (32), is in the form of

$$G_p(s) = \frac{0.1429z + 3.2857}{z^2 - 0.4936} \quad (33)$$

4 Comparing the Model with a Real System

In Fig.7. a graphic of a real DC motor speed is shown, obtained by using acquisition card LCK- 6013 which is over a block connector CB-68LP connected with a computer. By applying of program packet LABVIEW, speed samples have been recorded - that is, numbers of impulses in the chosen time interval $T = 0.05s$. These samples have been transformed into speed (rpm) by using relation

$$n(t) = \frac{60b(t)}{K_n T} \text{ rpm} \quad (34)$$

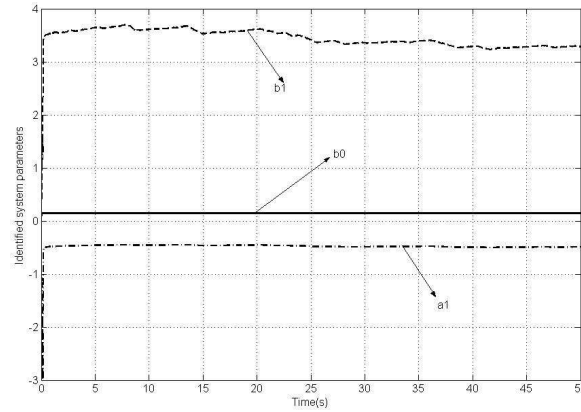

Fig. 6. Identified system parameters for the sampling period and DC motor supply voltage.

where $n(t)$ is speed (rpm), $b(t)$, is number of impulses in interval, and $K_N = 0.55$ is number of transparent segments on the optical encoder disk.

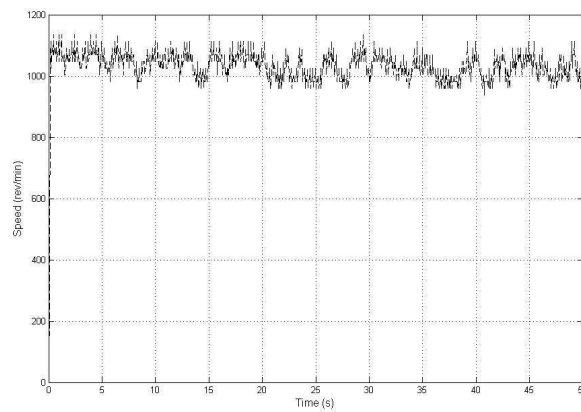

Fig. 7. DC motor speed at supply voltage of the motor - real system.

In order to compare the real system with the model obtained by method of identification, whose transfer function in the Z domain form (33), identified system has been simulated on a computer by using Simulink module of MATLAB program packet. Simulink model of the system with parameters calculated by system identification is shown in Fig.8.

Amplifier K is a transformer of the number of impulses in time interval $T = 0.05s$, into a motor speed given (rpm),

$$n(t) = \Omega(t) \frac{30}{\pi} \quad (35)$$



Fig. 8. Simulink model of the system with parameters calculated by identification of the system.

where $\Omega(t)$ is motora speed (rad/s). Fig.9. shows the obtained graphic of a motor speed.

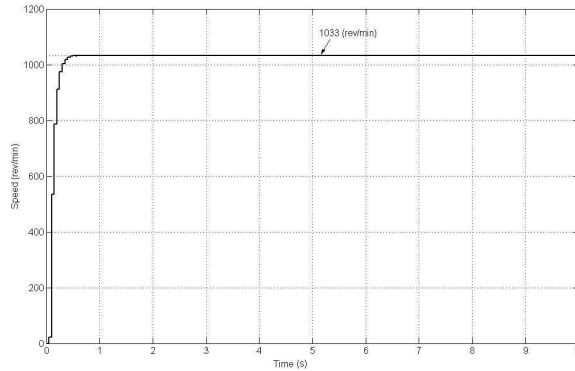

Fig. 9. Motor speed obtained on the basis of identified system parameters.

For a DC motor whose parameters have been identified, a factor gain K_m and time constant T_m need to be calculated. On the basis of (31) and (32) it appears that

$$T_m = 0.07 \text{ s} \tag{36}$$

One meaning value is not obtained for the gain factor K_m . As, on the basis of (31), (32), and (36) it appears

$$K_{m1} = 1.14 \text{ (rad/s)/V} \quad \text{i} \quad K_{m2} = 34.858 \text{ (rad/s)/V.} \tag{37}$$

Let's adopt

$$K_m = 15.46 \tag{38}$$

for which value the obtained graphic of motor speed is most approximately similar to the graphic in Fig.9.



Fig. 10. Simulink model of a DC motor of transfer function.

So, motor transfer function is of the form

$$G_m(s) = \frac{15.46}{0.07s + 1} \quad (39)$$

A graphic of DC motor speed of transfer function (39) is presented in Fig.11.

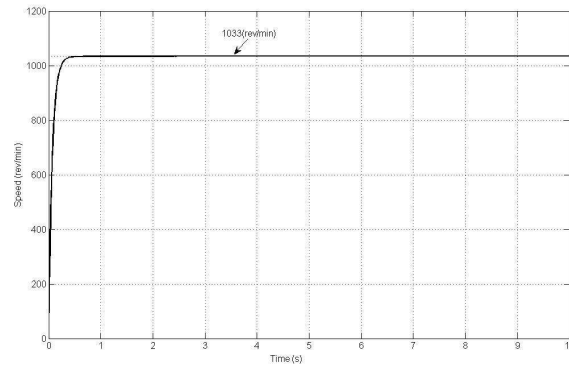

Fig. 11. Motor speed of transfer function.

By comparing a graphic of real motor speed -Fig.7. and a graphic of speed of identified system in Z and S domains, Fig.9. and Fig. 11., according to the shapes of obtained graphics, it can be concluded that, in spite the complexity of its character, a satisfying quality of DC motor parameters identification has been achieved.

5 Conclusion

This paper has investigated the issues involved in applying Recursive Least Squares method in parameters identification of DC motor models. The issues have been considered both theoretically and experimentally. The experimental work was performed on a DC motor with an optical encoder as an output of the system. The validity of the proposed method was shown by simulation and experiments. By comparing a graphic of real motor speed and a graphics of speed of investigated models in a Z and S domains it can be concluded that a satisfying quality of DC motor parameters identification has been achieved.

References

- [1] M. R. Stojic, *Digital Control Systems*. Beograd: Akademska Misao, 1998, (in Serbian).

- [2] P. E. Wellstead and M. B. Zarrop, *Self-tuning systems*. University of Manchester, Institute of Science and Technology, UK: Control Systems Centre, 1999.
- [3] D. M. Stojanović, *Introduction to Automatic Control Systems*. Čačak: Technical Faculty Čačak, 1995, (in Serbian).
- [4] I. Ahmed, "Implementation of self tuning regulators with tms320 family of digital signal processors," in *Proc. MOTORCON '88*, Houston, Texas, Sept. 198, pp. 248–262.
- [5] S. Meshkat, *Advanced Motion Control*. Motion Research, Inc., 1975.
- [6] "Controltoolbox user's guide." [Online]. Available: www.mathworks.com