

Detection of Chemical Vapors Using Oscillator with Surface Acoustic Wave Sensor

Tomislav M. Stojić

Assistant Professor
University of Belgrade
Faculty of Mechanical Engineering

Marija F. Hribšek

Professor
Institute Goša, Belgrade

Zoran Filipović

Assistant Professor
Institute Goša, Belgrade

Surface Acoustic Wave (SAW) sensors demonstrate superior sensitivity in detection of chemical agents. Due to their solid state design and fabrication compatible with modern technologies, SAW chemical sensors are extremely reliable. The sensor is modeled as a two-port device with parts represented by equivalent circuits. Change of output frequency as a function of vapor concentration is calculated. The oscillator circuit with SAW sensor in the feedback loop is designed. The SAW sensor is used for modifying the oscillator frequency. The presence of chemical vapor is then detected by monitoring this frequency shift.

Keywords: SAW sensor, chemical vapor sensing, oscillator.

1. INTRODUCTION

In the last two decades surface acoustic wave (SAW) chemical vapor sensors have found numerous applications due to their compact structure, high sensitivity, small size, outstanding stability, low cost, fast real-time response, passivity, and above all their ability to be incorporated in complex data processing systems [1-3].

The basic principle of the SAW sensors is the reversible absorption of chemical vapors by a solvent coating which is sensitive to the vapor to be detected. The SAW sensors have been able to distinguish a wide range of chemical vapors [1]. A surface acoustic wave is a type of mechanical wave motion which travels along the surface of a solid material, referred to as a substrate. The amplitude of the wave decays exponentially with the distance from the surface into the substrate, so that most of the wave energy is confined to within one wavelength of the surface [4,5].

The analysis of the SAW devices can be approached to in three ways: (1) exact analysis by solving the wave equation, (2) approximate analysis by means of equivalent electrical circuits, and (3) approximate analysis via the delta function model [6]. It is well known that the exact analysis of the SAW devices using surface wave theory is very complex (even in the case of a free surface) [4-8].

The presented approximate method uses equivalent circuit models for interdigital transducers (IDTs), where the analysis tools known in electrical engineering can be applied. A recently proposed modeling algorithm, described in details in [9], for the analysis of chemical SAW sensors, based on the electrical equivalent circuits method, is here just briefly presented. The algorithm gives explicit general relations between electrical signals, voltages or frequencies, and vapor detection estimations taking into account the properties of the real

SAW devices, which are usually neglected [9]. The whole sensor is modeled as a two-port network (quadripole) consisting of three parts: (1) the input interdigital transducer, (2) the delay line that is the sensing part, and (3) the output interdigital transducer. The transducers are modeled as three-port networks and the delay line as a two-port network.

The first part of this paper deals with the basic principles of the SAW sensor operation and the modeling approach. In the second part the oscillation circuit with the embedded SAW sensor is presented. The sensor is now modeled as one-port network using its input impedance. The variation of the oscillator frequency caused by impedance parameter changes is shown in the form of simulation results.

2. BASIC PRINCIPLES OF SAW SENSOR OPERATION

A transversal SAW chemical sensor can be schematically presented as in Figure 1. It consists of two interdigital transducers on a piezoelectric substrate, such as quartz.

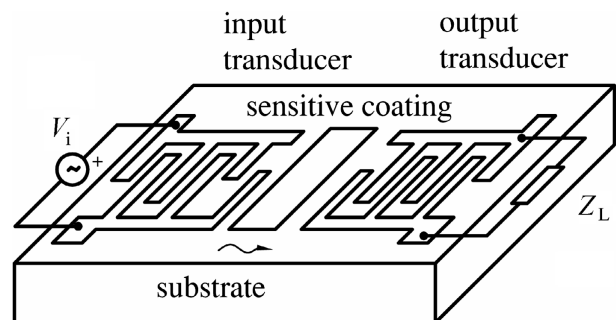

Figure 1. The basic configuration of a chemical SAW sensor [9]

A chemically sensitive thin layer is placed between the interdigital transducers on the top surface of the piezoelectric substrate. The surface wave is induced by an electrical signal applied to the input IDT.

The output signal (voltage) is taken from the output IDT. The velocity and attenuation of the wave are sensitive to mass and viscosity of the thin layer. The purpose of the thin layer (a polymer film) is to absorb chemicals of interest. When the chemical is absorbed,

Received: February 2011, Accepted: April 2011

Correspondence to: Tomislav Stojić
Faculty of Mechanical Engineering,
Kraljice Marije 16, 11120 Belgrade 35, Serbia
E-mail: tstojic@mas.bg.ac.rs

the mass of the polymer increases causing a change in velocity and phase of the acoustic signal, which causes a change in amplitude and frequency of the output voltage at the load impedance Z_L . Acoustic absorbers (not shown in Figure 1) should be appropriately placed on the substrate edges to damp unwanted SAW energy and eliminate spurious reflections that could cause signal distortions.

The IDTs are identical with uniformly spaced electrodes of equal lengths and equal ratio of electrodes width and spacing. The number of electrodes defines the frequency bandwidth of a SAW device. The wavelength corresponding to the center frequency equals the distance between the electrodes of the same polarity. The center frequency and the bandwidth are determined by the IDTs geometry and the substrate type.

The middle part of a SAW sensor is a delay line (DL), generally treated as lossless. However, its losses can be neglected only for lower frequencies and small delays (small distances between the transducers). The transfer function of the delay line is a normally assumed unity, although this may not be true for high frequencies ($f > 0.5$ GHz), or if there are films in the propagation path [10]. In communications, in electrical filtering applications, the distance between the IDTs is small. Quite opposite, in chemical sensors this part is essential and must have a certain length, usually 100–200 wavelengths [5], which should be taken into account.

2.1 Modeling of SAW Chemical Sensors

The configuration presented in Figure 1 can be modeled by a general equivalent electromechanical circuit given in Figure 2.

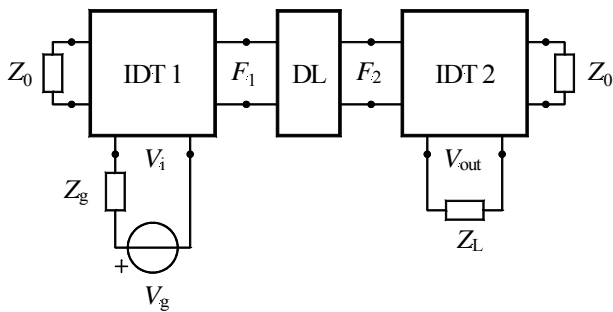

Figure 2. The equivalent circuit of a SAW sensor

The IDTs are three-port networks and the sensing part is a two-port network designated by DL in Figure 2. The characteristic SAW acoustic impedance of the unloaded substrate is designated by Z_0 and the acoustic impedance due to the mass loading of the thin film is Z_m :

$$Z_0 = A\rho_s v \quad (1)$$

$$Z_m = A_m\rho_m v \quad (2)$$

where A is the substrate cross-sectional area through which the waves propagate, ρ_s is the mass density of the piezoelectric substrate, v is the SAW velocity in the piezoelectric substrate, A_m is the cross-section area of the thin film, and ρ_m is the mass density of the film. $Z_g = R_g$ and $Z_L = R_L$ are purely resistive electrical impedances of the generator and the electrical load, respectively.

The chemical sensor operates near the center frequency and the IDTs are uniform with equal length electrodes [9]. In that case, the IDT driving-point admittance at the electrical port, $Y_{\text{IDT}} = G_a(f) + jB_a(f) + j2\pi fC_0$, $j = \sqrt{-1}$, where C_0 is the static capacitance, can be calculated using well-known formulas [10].

$$G_a(f_0) = 8k^2 f_0 C_s W_a N_p^2, \quad B_a(f_0) = 0 \quad (3)$$

where k is the piezoelectric coupling coefficient, f_0 is the center frequency, C_s is the capacitance per unit electrode length, W_a is the electrode length, N_p is the number of electrode pairs.

The output voltage across the load V_{out} is proportional to the mass loading of the sensing part. First, the output voltage in the presence of sensing material (polymer without vapor) is calculated and it serves as a reference voltage V_b , also referred to as the baseline voltage. The difference of the output voltage in the presence of vapor and the reference voltage is proportional to the vapor concentration. Usually, two equal SAW sensors are used: one is vapor-free and serves as a reference; the other one is exposed to the vapor and actually performs the sensing function. The two SAW sensors are embedded into electrical oscillator circuits and the frequency shift between the oscillators is proportional to the gas concentration. Using an electronic circuit called the mixer the voltage proportional to the vapor concentration is obtained from the frequency shift. According to Figure 2, the electrical transfer function can be expressed as follows:

$$T(f) = \frac{V_{\text{out}}}{V_g} = \frac{V_{\text{out}}}{F_2} \frac{F_2}{F_1} \frac{F_1}{V_g} \quad (4)$$

where F_1 and F_2 are mechanical forces.

Since the transducers are identical and the sensors work close to a resonance, a much simpler expression can be used [9]:

$$|T(f_0)| = |T_{13}(f_0)|^2 \left| \frac{F_2}{F_1} \right| \quad (5)$$

where $T_{13}(f) = V_{\text{out}}/F_2$ represents the transfer function of the transducer.

At resonance and negligible losses, $F_2/F_1 = 1$ and $|T_{13}(f_0)|^2 = 1/4 \approx -12$ dB. Therefore, the relative variation of the output voltage V_{out} due to the mass loading is equal to the relative variation of F_2 . The delay line of Figure 2 can be schematically represented as shown in Figure 3.

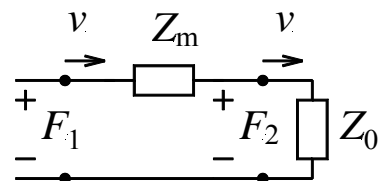

Figure 3. The equivalent circuit of a mass loaded delay line

By analogy between electrical and mechanical quantities [9] from Figure 3 directly follows:

$$\frac{\Delta F_2}{F_{20}} = \frac{\Delta v}{v} = \frac{F_2 - F_{20}}{F_{20}} = \frac{-Z_m}{Z_0 + Z_m} \approx \frac{-Z_m}{Z_0} \Big|_{Z_m \ll Z_0} \quad (6)$$

where F_{20} denotes F_2 without mass loading, and v is the corresponding wave velocity.

Using (1), (2) and (6) and the well-known relation between frequency, velocity and wavelength the frequency shift due to the mass loading can be calculated as:

$$\frac{\Delta f}{f_0} = \frac{\Delta v}{v} = \frac{-Z_m}{Z_0} = -\frac{\rho_m h_m}{\rho_s \lambda_0} K_w \quad (7)$$

where ρ_m and h_m are the density and thickness of the thin layer, ρ_s is the density of the piezoelectric substrate, and K_w is a technological coefficient [9]. The components of the wave decay exponentially inside the substrate and the penetration is of the order of one wavelength. Therefore, in (7), instead of the substrate thickness, one wavelength λ_0 is used. From the last equation Δf can be determined as:

$$\Delta f = -\frac{\rho_m h_m}{\rho_s v} f_0^2 K_w \quad (8)$$

The frequency change, due to the polymer sensing film (without vapor) can be determined as:

$$-\frac{\Delta f}{f_0} = \frac{\rho_p h_p}{\rho_s v} f_0 K_w \quad (9)$$

where ρ_p and h_p are the density and thickness of the polymer, respectively.

When vapor is absorbed, an additional frequency change occurs. Using the same reasoning and the fact that h_p is much smaller than λ_0 , the frequency change due to vapor in sorbent phase, can be calculated as:

$$-\frac{\Delta f_{\text{vap}}}{f_0} = \frac{\rho_{\text{vap}} h_p}{\rho_s v} f_0 K_w \quad (10)$$

where ρ_{vap} is the density of the vapor in the sorbent phase. Since the reference frequency shift without vapor Δf is known, (9), the last equation can be expressed as follows:

$$\frac{\Delta f_{\text{vap}}}{f_0} = \frac{\rho_{\text{vap}}}{\rho_p} \frac{\Delta f}{f_0} \quad (11)$$

From (11) the concentration of the chemical compound in vapor phase can be predicted using the known relation between the concentrations in sorbent and vapor phases [11]:

$$K = \frac{C_s}{C_v} \quad (12)$$

where K is the partition coefficient, C_s is the concentration of the chemical compound in sorbent phase (in the sorbent coating [8]), and C_v is the concentration of the chemical compound in vapor phase (concentration in the ambient [8]). The frequency shift Δf_{vap} as a function of concentration C_v can be obtained as [9]:

$$\Delta f_{\text{vap}} = K C_V \frac{\Delta f}{\rho_p} = K C_V \frac{h_p}{\rho_s v} f_0^2 \quad (13)$$

Equations (10) – (13) are derived for a delay line with negligible propagation losses.

2.2 SAW sensor as an equivalent two port network

The SAW sensor in terms of electricity can be seen as equivalent two-port network (quadripol) [9], shown in Figure 4. The input voltage V_{in} is the voltage at the ends of the first, input transducer (IDT1), and the output voltage V_o is the voltage at the second, output transducer (IDT2). The output transducer is terminated with characteristic impedance $Z_p = 50 \Omega$.

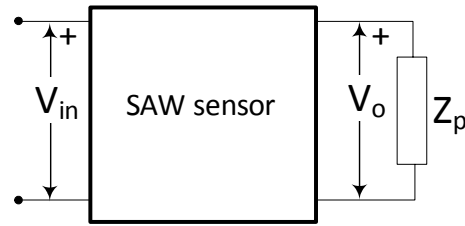

Figure 4. SAW sensor as a two port network

Electrical parameters of this equivalent quadripol can be calculated in different ways [6,9]. Input admittance is given by:

$$Y_{\text{in}} = G_a(f) + jB_a(f) + j2\pi f C_T \quad (14)$$

where are:

$$G_a(f) = 2f_0 C_0 k^2 \left(\text{tg} \frac{\theta}{2} \sin \frac{N\theta}{2} \right)^2$$

$$B_a(f) = f_0 C_0 k^2 \text{tg} \frac{\theta}{2} \left(2N + \text{tg} \frac{\theta}{2} \sin N\theta \right)$$

$$\theta = \frac{2\pi f}{f_0} \text{ and } C_T = N C_0 \quad (15)$$

N is the number of electrode pairs of interdigital transducers, C_0 is capacitance of one pair of electrodes, f_0 the resonance frequency and k piezoelectric constant of the substrate [9]. At the resonant frequency B_a is equal to zero and G_a is given by (3). In this case, viewed from the input terminals (with the voltage V_{in}), our quadripol acts as one-port network well described with its input impedance (admittance) Z_{in} (Y_{in}), shown in Figure 5.

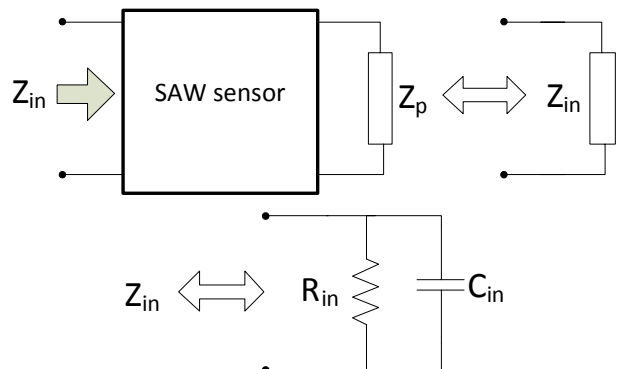

Figure 5. Input impedance of an equivalent quadripol

For the designed chemical sensor with the central frequency of about 80 MHz, the input impedance at the resonant frequency, calculated by the above-described algorithm [9], can be modeled by parallel connection of one resistor with resistance $R_{in} = 50 \Omega$ and one capacitor with capacitance $C_{in} = 3.34 \text{ pF}$.

3. SIMULATION RESULTS

The simulation is performed with the software package National Instruments Multisim v11.0 [12]. Modified Colpitts oscillator [13] with the output voltage taken from the emitter is shown in Figure 6. The values of all used components are indicated directly on the figure. The output of the oscillator is terminated with characteristic resistance $R_{out} = 50 \Omega$ due to impedance matching. Virtual oscilloscope XSC1 is used for viewing the waveform of output voltage, and virtual measuring probe *Probe1* is used for real time monitoring of some output voltage parameters.

Reference oscillator contains the SAW sensor that is not exposed to the chemical vapor. The equivalent input impedance of unloaded SAW sensor ($R_{in} \parallel C_{in}$) is subsequently marked with the red dashed frame. The parameters of sensor input impedance affects own resonant frequency of Colpitts oscillator, and the new oscillation frequency with embedded sensor is in our case 80.9 MHz, as is shown in the probe window. The effective (rms) value of the output voltage is $V(\text{rms}) = 1.32 \text{ V}$, and the peak to peak voltage is $V(\text{pp}) = 3.47 \text{ V}$. Output voltage waveform is shown in Figure 7.

The sensing oscillator, drawn on Figure 8, is identical to the reference oscillator, the only difference is that this time the loaded SAW sensor, i.e. the sensor exposed to the chemical vapor is used. It is assumed that

vapor exposure causes the increasing of input resistance R_{in} , from 50 to 60 Ω , while the input capacitance C_{in} remains unchanged. This is a realistic assumption because the input capacitance consists predominantly of static capacitance between the electrodes and between the electrodes and the housing, and it is very little subjected to change due to vapor exposure.

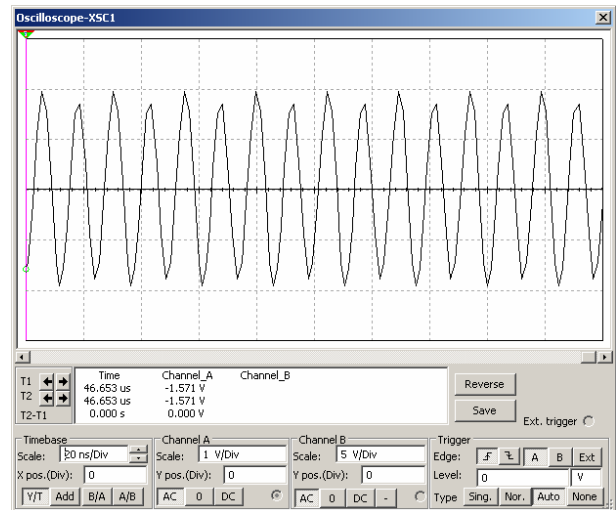

Figure 7. Output voltage waveform

As a result of vapor exposure, the input resistance of the SAW sensor impedance is changed causing frequency shift of sensing oscillator by $\Delta f_{osc} = f_0 - f_{0s} = 80.9 - 80.8 = 0.1 \text{ MHz}$ compared to the reference oscillator. The waveform of output signal remains practically the same, so it is not shown here.

The frequency shift between the reference and the sensing oscillator can be automatically detected by frequency mixer, as is shown in block schematic in Figure 9.

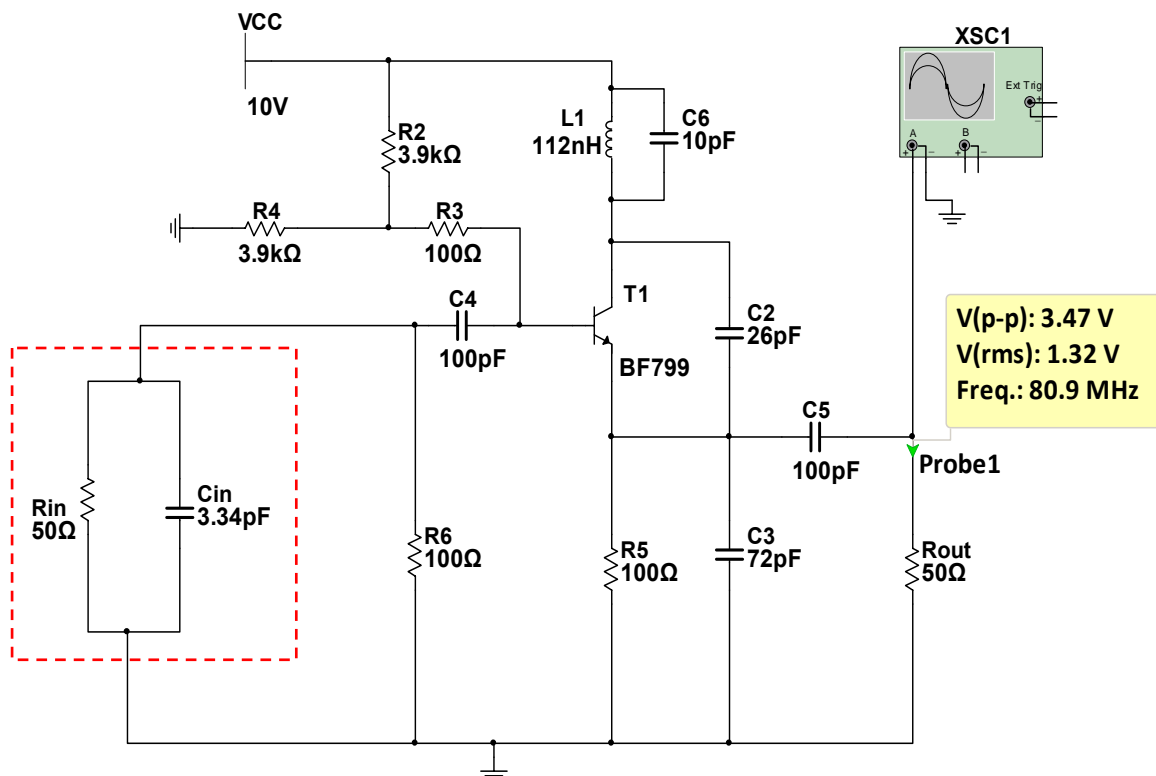

Figure 6. Complete reference oscillation circuit

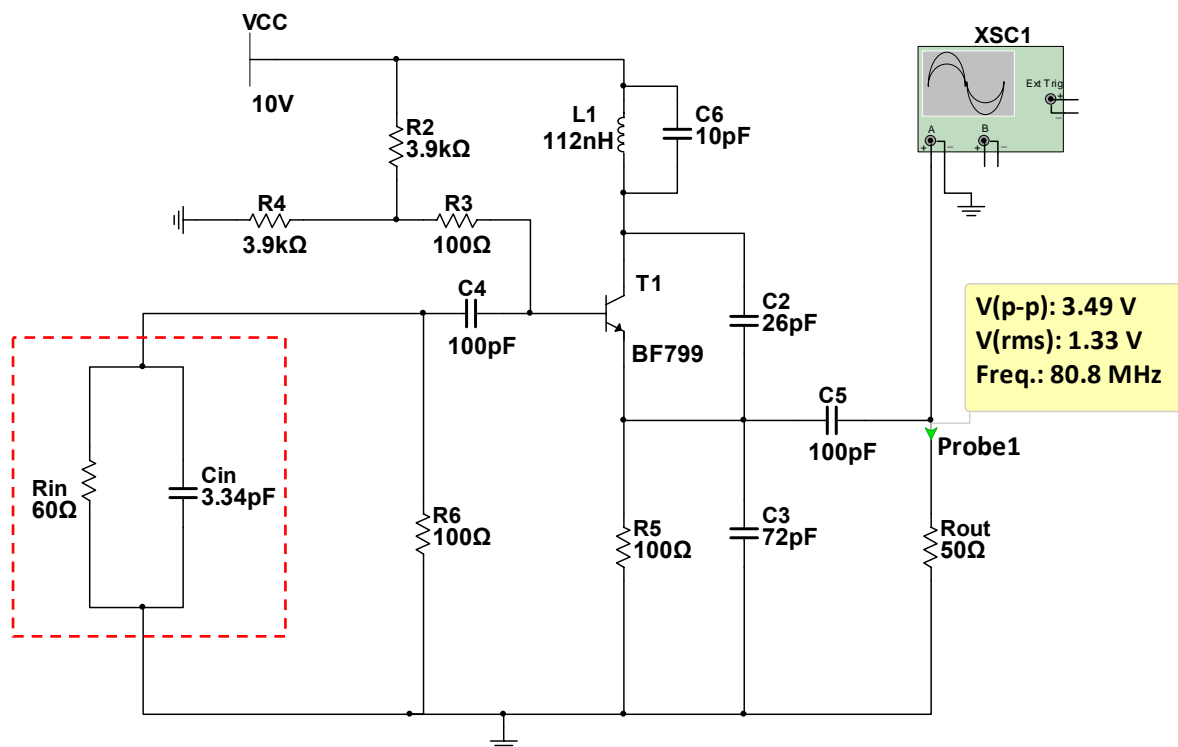

Figure 8. Complete sensing oscillation circuit

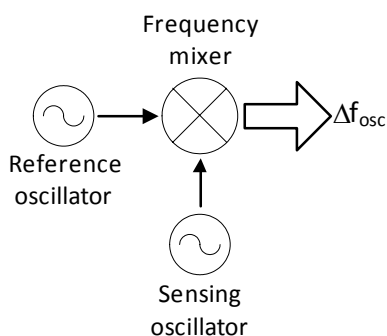

Figure 9. Automatic detection of frequency shift

The relative frequency change, $\Delta f_{osc}/f_0 = 0.1/80.9 \approx 0.12\%$, is in accordance with the estimated and experimentally confirmed frequency shifts due to vapor exposure, as stated in [9].

4. CONCLUSIONS

This paper presents a simulation of a system for the detection of chemical vapors using the SAW chemical sensors. The modified Colpitts oscillator is designed. The SAW sensor embedded in the feedback loop changes its input impedance according to the vapor exposure. This change causes further frequency shift of the oscillator frequency. By measuring the frequency shift between reference (not exposed) and sensing (exposed to the vapor) oscillators, it is possible to detect the presence (or the absence) of chemical vapor in the air. The simulation results confirm this assumption.

ACKNOWLEDGMENT

The authors would like to thank the Ministry of Science and Technological Development of Serbia for financial support.

REFERENCES

- [1] Ho, C.K., Lindgren, E.R., Rawlinson, K.S., McGrath, L.K. and Wright, J.L.: Development of a surface acoustic wave sensor for in-situ monitoring of volatile organic compounds, *Sensors*, Vol. 3, No. 7, pp. 236-247, 2003.
- [2] Wohltjen, H. and Dessy, R.: Surface acoustic wave probe for chemical analysis. I. Introduction and instrument description, *Analytical Chemistry*, Vol. 51, No. 9, pp. 1458-1464, 1979.
- [3] Wohltjen, H.: Mechanism of operation and design considerations for surface acoustic wave device vapour sensors, *Sensors and Actuators*, Vol. 5, No. 4, pp. 307-325, 1984.
- [4] Farnell, G.W.: Elastic surface waves, in: Matthews, H. (Ed.): *Surface Wave Filters*, John Wiley and Sons, New York, 1977, pp. 1-55.
- [5] Martin, S.J., Frye, G.C. and Senturia, S.D.: Dynamics and response of polymer-coated surface acoustic wave devices: Effect of viscoelastic properties and film resonance, *Analytical Chemistry*, Vol. 66, No. 14, pp. 2201-2219, 1994.
- [6] Milsom, R.F., Redwood, M. and Reilly, N.H.C.: The interdigital transducer, in: Matthews, H. (Ed.): *Surface Wave Filters*, John Wiley and Sons, New York, 1977, pp. 55-108.
- [7] Morgan, D.P.: *Surface-Wave Devices for Signal Processing*, Elsevier, London, 1985.
- [8] Ballantine, D.S., White, R.M., Martin, S.J., Ricco, A.J., Zellers, E.T., Frye, G.C. and Wohltjen, H.: *Acoustic Wave Sensor: Theory, Design, and Physico-Chemical Applications*, Academic Press, San Diego, 1997.

- [9] Živković, Z., Hribšek, M. and Tošić, D.: Modeling of surface acoustic wave chemical vapor sensors, *Journal of Microelectronics, Electronic Components and Materials – Informacije MIDE M*, Vol. 39, No. 2, pp. 111-117, 2009.
- [10] Golio, M.: *The RF and Microwave Handbook*, CRC Press, Boca Raton, 2008.
- [11] Grate, J.W. and Klusty, M.: *Surface Acoustic Wave Vapor Sensors Based on Resonator Devices*, Naval Research Lab, Washington, 1991.
- [12] NI Multisim v11.0, academic version – Software package, National Instruments, Austin, <http://www.ni.com/academic/multisim.htm>
- [13] *SAW-Components: Design-Guide for the SAW Oscillator, Optimisation for Best Frequency Stability, Fast Start Up Time and Ghost-Less Working, Application Note 25*, EPCOS, Munich, 2008.

**ДЕТЕКЦИЈА ГАСОВА ПОМОЋУ
ОСЦИЛАТОРА СА СЕНЗОРОМ СА
ПОВРШИНСКИМ АКУСТИЧКИМ ТАЛАСОМ**

**Томислав М. Стојић, Марија Ф. Хрибшек, Зоран
Филиповић**

Сензори са површинским акустичким таласима (ПАТ) испољавају супериорну осетљивост при детекцији хемијских агенаса. Због непостојања покретних делова и израде компатибилне са модерним технологијама, ПАТ хемијски сензори су веома поуздани. Сензор је моделован као двопортни уређај чији су делови представљени еквивалентним колима. Израчуната је промена излазне фреквенције у функцији концентрације гаса. Пројектовано је осцилаторно коло са ПАТ сензором у грани повратне спреге. ПАТ сензор се користи за модификовање фреквенције осцилација. Присуство хемијских испарења се онда директно детектује праћењем овог фреквенцијског помака.