

Miodrag Stoimenov

Associate Professor
University of Belgrade
Faculty of Mechanical Engineering

Branislav Popkonstantinović

Associate Professor
University of Belgrade
Faculty of Mechanical Engineering

Ljubomir Miladinović

Associate Professor
University of Belgrade
Faculty of Mechanical Engineering

Dragan Petrović

Associate Professor
University of Belgrade
Faculty of Mechanical Engineering

Evolution of Clock Escapement Mechanisms

The paper presents and explains the evolution of details design of the clock escapement mechanisms through the ages. As particularly significant, the following mechanisms are emphasized: the crown wheel (verge & foliot), anchor recoil, deadbeat and detached escapements, and their variations – gravity and chronometer escapements, as well as the English and Swiss lever watch escapements. All important geometrical, kinematical and dynamical properties and the influence of these properties on the clock accuracy are explained.

Keywords: clock, escapement, evolution, mechanism, lever.

1. INTRODUCTION

This work is aimed at a qualitative analysis of advancement in escapement mechanism structural definition and development of a timepiece over the past seven centuries. This study covers the following issues a) *the crown wheel, the verge and foliot*, b) *the recoil anchor escapement*, c) *deadbeat escapements*, and d) *detached escapements*. Measure of the effectiveness in the regulator horological properties could be specified as follows: a) the level of constructive and dynamic separation of impulse and locking function, b) duration of the interaction between the rate regulator and the oscillator [1], and c) effects of the forces of impulse and locking function on fluctuation of the pendulum T period composed of eigen-oscillations and balance wheels correction [1], (can be compared with the absolute pace and accordingly appears as: isochronous, tachy-chronous and brady-chronous); isochronous: ίσοσ – equal, χρόνος – time, no delay; tachy-chronous: ταχύς – fast, shortens, $\Delta T \downarrow$ (faster); brady-chronous: βραδύς – slow, prolongs, $\Delta T \uparrow$ (slower).

2. CROWN WHEEL, VERGE AND FOLIOT

The crown wheel, verge and foliot commonly referred to as the *verge-and-foliot* mechanism [2] is a speed regulator of the earliest, old timepieces that emerged in the second half of the 13th century Europe. The device is believed to date from 1273 and is attributed to the French builder Villard de Honnecourt, 13th century. The earliest detailed description of this mechanism was given by Giovanni de Dondi, 1318-1389, a professor of astronomy from Padua, in his work *Il Tractus Astarii*, 1364 [3].

Figure 1 displays the verge-and-foliot mechanism. To understand the principle of its operation, it should be pointed out for a start that the early timepieces, whose speed was regulated by this mechanism, did not have an

oscillator with the restoring force and standardized pace. The crown wheel rate, acted upon by driving torque, is regulated only by the foliot inertia with a rather unpredictable error. When the crown wheel is rotating, the pallet of the verge is caught by one of the wheel's teeth, rotating the verge and a solid foliot in one direction and leading to engagement of the opposite tooth with the second pallet [4]. Due to the foliot inertia, that next tooth stops the wheel's motion, and the wheel with its eigen driving torque finally stops the rotation of the foliot too. And again, the crown wheel acts upon the engaged tooth, so that the foliot rotating cycle is repeated, however, in opposite direction.

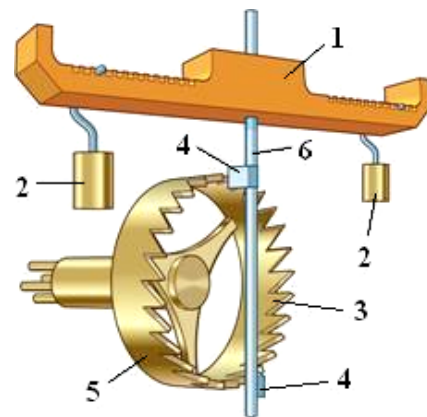

1 – Foliot; 2 – Weight; 3 – Crown wheel tooth; 4 – Pallet; 5 – Crown wheel; 6 – Verge

Figure 1. Verge & Foliot

As the foliot is not exactly an oscillator, the rate of medieval timepieces was largely affected by all possible disturbances. It was only under the influence of works by Christiaan Huygens, 1629 – 1695, that from 1656 the pendulum replaced the foliot in timepieces, and balance wheels with pivots were incorporated from 1658 [3]. Those technical accomplishments contributed significantly to the accuracy of timepiece running, reducing the error from several hours a day to several tens of minutes a day. The elimination of the foliot and introduction of the first real oscillators changed to the full the character of the rate regulator itself: with the pendulum introduced, the crown wheel and verge obtained all essential characteristics of the recoil

Received: September 2011, Accepted: December 2011

Correspondence to: Dr Miodrag Stoimenov
Faculty of Mechanical Engineering,
Kraljice Marije 16, 11120 Belgrade 35, Serbia
E-mail: mstoimenov@mas.bg.ac.rs

escapement. The following section analyzes recoil anchor escapements.

3. RECOIL ANCHOR ESCAPEMENTS

A speed regulator of the verge-and-foliot type modifies wide pendulum oscillation amplitudes (even higher than $\pm 50^\circ$), which significantly increases the effect of circular error on the total isochronism drop [5]. It was the need to reduce the pendulum vibration amplitudes that resulted in introducing new types of rate regulators into the timepiece design. These were anchor escapements with recoil action, whose design was accounted for by an English clockmaker William Clement and British scientist Robert Hook, 1635 – 1703, in 1670. That same year the clockmaker Joseph Knibb, 1640 – 1711, built the first clock with the Clement-Hook anchor escapement in Oxford [4].

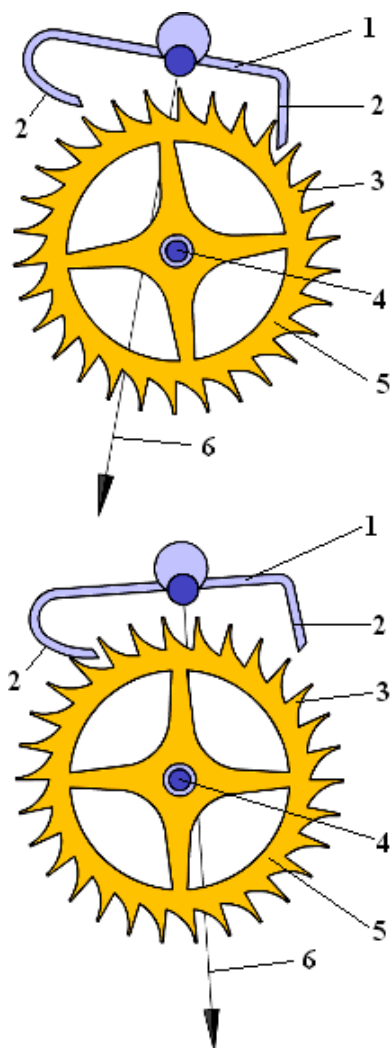

1 – Anchor; 2 – Impulse locking surfaces; 3 – Escape wheel tooth; 4 – Escape wheel shaft; 5 – Escape wheel; 6 – Pendulum axis

Figure 2. Recoil anchor escapements

Figure 2 [6] shows the basic geometry and operation of the recoil anchor regulator, while Fig. 3 also presents the corresponding diagrams of moment interactions that attitudes on indicators of its horological characteristics derive from. The diagram $G \cdot l \cdot \sin \phi$ (G – pendulum weight) presents the moment of the pendulum gravity

restoring force, M is the moment of a force of the rate regulator impulse function and Ω is the moment of a resistance force generated by a regulator and acts upon the pendulum, and all three relative to the point of suspension and depending on the pendulum swing angle ϕ . The immediate direction is positive. When a pendulum moves from the left amplitude position 1, through the equilibrium position 0, as far as the position 2 the moment M acts in the direction of its rotation. At point 2, the moment changes the direction and causes the pendulum to stop as far as the right amplitude position 3, while the escape wheel is subject to backward motion, i.e. recoil. The cycle is now repeated, but from the right to the left, through points 3-0-4-5 \rightarrow 1. The moment of a force of dry friction Ω always has the anti-clockwise direction to the pendulum. In sections 1-0-2 and 3-0-4 the regulator realizes the impulse function, and in sections 2-3 and 4-5 \rightarrow 1 the locking function with recoil. It is inferred, from above mentioned, that there is no separation between impulse and locking functions!

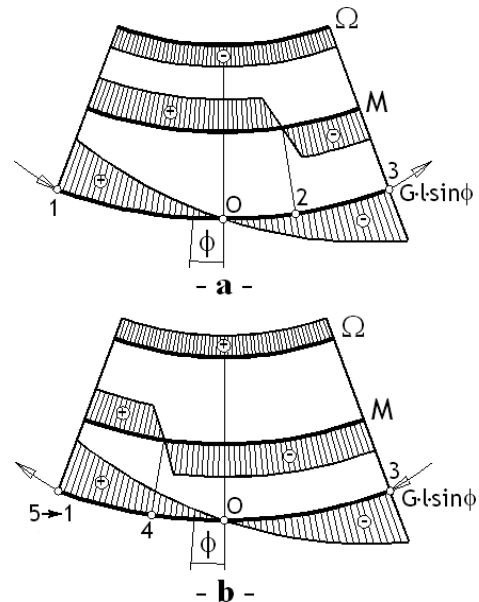

Figure 3. Diagrams of moment interactions for recoil anchor escapement

They are both realized on the same anchor pallets' impulse-locking surfaces, however, in different phases of the pendulum oscillation period. The interaction between the rate regulator and the oscillator is permanent. The pendulum does not vibrate freely at any moment, but under direct and constant influence of the driving torque forces. When a pendulum moves from the left to the right, moments M and $G \cdot l \cdot \sin \phi$ are unidirectional, which causes tachy-chronous effect, but mutually opposite in section 0-2, which is brady-chronous. The theory of oscillations proves that the pendulum oscillation period is shortened if the moments of the restoring and forced forces are of the same direction, and vice versa! In the second semi-cycle, when a pendulum moves from the right to the left, moments M and $G \cdot l \cdot \sin \phi$ are in the zones 3-0 and 4-5 \rightarrow 1 and are of the same direction, which is tachy-chronous, but mutually opposite in section 0-4, which is brady-chronous. The effect of dry friction moment of force is integral-isochronous in each semi-cycle. There prevails

tachy-chronism overall, which means that every increase of the driving moment leads to diminished oscillation period of a pendulum and acceleration of the clock rate.

All mentioned characteristics of the recoil escapements are not satisfactory in terms of horology, which is completely accounted for by the fact that they were developed at the very beginning of their long evolution. Yet, compared to the verge-and-foliot mechanisms, those mechanisms meant progress since they reduced the pendulum amplitude from $\pm 50^\circ$ to $\pm (5^\circ - 10^\circ)$, therefore, in proportion to the reduction of amplitude, the effect of circular error too.

4. DEADBEAT ESCAPEMENTS

The design solution of separating impulse from locking function in anchor regulators, probably the most important in the entire history of the science and skill of clock-making, was accomplished in 1675 by Thomas Tompion, 1639 – 1713, the Father of British Horology, according to the idea of the mathematician and astronomer Richard Towneley, 1629 – 1707. Honourable George Graham, 1674 – 1751, Tampon's disciple and of the time a Great Master of the Honourable Clock-makers' Guild in London, improved this device in 1715 and thus made possible its massive use. [4] This is the so-called deadbeat escapement, whose shape and operation are presented in Fig. 4 [6]. Unlike the recoil anchor escapement, in this case, the pallets have clearly separated locking from impulse surfaces. Locking surfaces are portions of circular cylinders with an axis passing through the anchor suspension point. This design characteristic cancels the moment of the locking function reaction force relative to the suspension point, whereby the escape wheel recoil is completely eliminated [1]. Impulse surfaces are flat and adjusted to transfer force only during pendulum direct transition through the equilibrium position. Figure 5 also gives the diagrams of the moment of interactions that will be used to deduce conclusions on horological characteristics of deadbeat escapements. (Notations $G \cdot l \cdot \sin \varphi$, M and Ω have been explained above in the diagrams of interactions.) In the first semi-cycle, when the pendulum swings from the left amplitude position 1 to the equilibrium position 0, moment M is acting only in section 2-0-3, and in the second semi-cycle when the pendulum swings from position 4 to 0, it is acting in section 5-0-6. In these positions the regulator performs the impulse function (the contact between escape wheel tooth and pallet impulse surface), and in other positions it performs the locking function. The moment of friction force Ω is present almost all the time and is always directed anti-clockwise to the pendulum rotation. If perfectly accurate building of both the anchor and the escape wheel were possible, diagrams M and Ω would be symmetrical relative to the equilibrium position 0 and the regulator would be isochronous. In order to ensure safe engagement of the anchor pallets and escape wheel, despite unavoidable errors in clock-making, it is necessary to reduce the radius of cylindrical locking surface of the entry pallet and to increase it in the exit pallet. This alteration, although very slight, leads to effective reduction of the impulse surface that is engaged

with the escape wheel tooth in front of the equilibrium position both on the entry and exit anchor pallet. The described geometrical alteration has far-reaching effects on dynamic characteristics of rate regulation. In the first semi-cycle the effect of moment M is shorter in section 2-0 than in section 0-3, while in the second semi-cycle, M is acting shorter in section 5-0 than in section 0-6. As the total unidirectional action of moments M and $G \cdot l \cdot \sin \varphi$ (in section 2-0 and 5-0) is shorter relative to mutually opposite, the brady-chronous effect prevails. Similar holds for the moment of a force friction Ω . Due to design clearance between pallets' surfaces and wheel teeth, locking functions do not start to act as soon as the impulse functions are terminated at points 3 and 6, but at 3' and 6', so that the total unidirectional action of moments Ω and $G \cdot l \cdot \sin \varphi$ (in sections 0-4 and 0-7 \rightarrow 1) is shorter relative to mutually opposite (in sections 1-0 and 4-0). So, both moments, M and Ω , are acting integrally brady-chronously, which means that every increase of the driving moment causes augmentation of the pendulum oscillation period and deceleration of the rate of the clock.

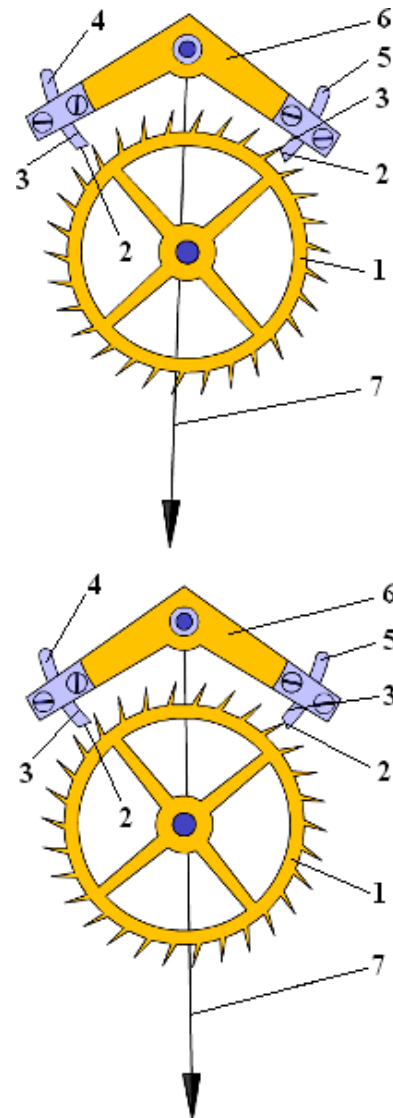

1 – Escape wheel; 2 – Pallet impulse surface;
3 – Pallet locking surface; 4 – Entry pallet; 5 – Exit pallet;
6 – Anchor; 7 – Pendulum axis

Figure 4. Deadbeat escapements

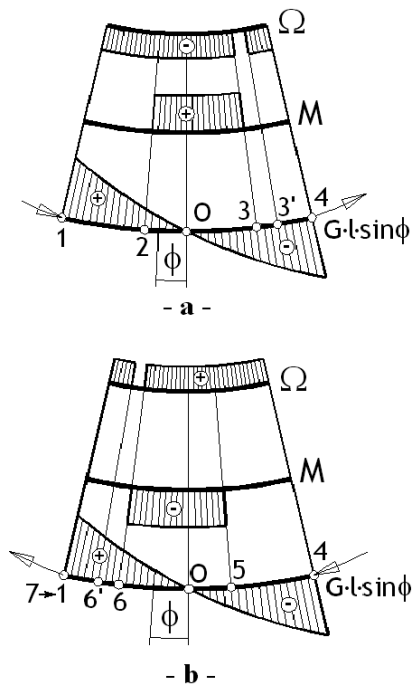

Figure 5. Diagrams of moment interactions for deadbeat escapement

Apart from the above analyzed operation of the Graham deadbeat anchor escapement, many other escapement mechanisms belong to this class of timepieces. Some of these incorporated in stationary (tower and wall) clocks are the Amant-Lepaute, 1741, 1750; the Brocot (Achille Brocot), 1849; the pin pallet escapement; and the names of some deadbeat regulators for portable timepieces (wrist and pocket watches) are the Tompion cylindrical (Tompion, 1695), duplex (Pierre Le Roy, 1748) and virgule (Lépine Jean Antoine, 1780) [4]. They all have identical or very similar characteristics, superior to recoil regulators: impulse function, constructively and dynamically separated from the locking function, with short duration, only during pendulum direct transition through the equilibrium position. With its subtler action, the outside force disturbs its eigen-oscillations. The pendulum vibration amplitude angle is small $\pm (2^\circ - 3^\circ)$, and the effect of circular error is slight. Quality clock-building makes brady-chronism almost unnoticeable etc. Due to mentioned design improvements, timepieces with deadbeat regulators exhibit rate error a day of only $\pm (3 - 5)$ seconds. However, there are still some disadvantages present: it stems from the diagrams of moment interactions that the oscillator is still, through the moments of friction forces, under the influence of the driving torque. Any variation of both driving force and the coefficient of friction on impulse and locking surfaces of pallets produces stochastically complicated effects on the alteration of the pendulum oscillation and oscillation period. The intention of horologists and clockmakers to eliminate this effect or at least to minimize it led to the invention of the so-called detached escapements, which are discussed in the section to follow.

5. DETACHED ESCAPEMENTS

Dissipation of the oscillator energy imposes the necessity for the regulator impulse function, while the regulation

of speed itself requires the action of its locking function. If impulse and locking functions are directly supplied by the clock's driving energy, then every change in drive causes variation of impulse, oscillator energy and frequency standard. The invention of the so-called detached escapements resulted from the idea that impulse and locking functions should be completely free from the direct influence of drive, or that the oscillator should be as long as possible free from any influence of the regulator. Realization of the former principle led to the design of the so-called gravity escapements, while the latter resulted in technical solutions for the chronometer regulators and the so-called English and Swiss free anchor escapement [4].

The earliest gravity escapement was designed in 1766 by English clock-makers Thomas Mudge, 1715 – 1794, and Alexander Cumming, 1732 – 1814. The device was improved by Captain Henry Kater, 1777 – 1835, about 1830 and J. M. Bloxam, a barrister, about 1850 [4]. However, the accomplishment of these preliminary ideas was rendered difficult due to unstable behavior of their locking function referred to as approximate tripping. This significant problem was finally solved by the great British horologist and lawyer Edmund Beckett Denison, 1st Baron Grimthorpe, Q. C., 1816 – 1905, with his invention of the famous “double three-legged gravity escapement” incorporated in the clock mechanism of Big Ben in 1856 [4]. To this day it regulates the running of the Great Clock of Westminster with extreme accuracy and reliability. For the stationary clocks of high accuracy, Denison designed another so-called four-legged escapement that will be used to illustrate the running of detached escapement mechanisms.

Figure 6 [6] displays the principle design components of the mentioned escapements, while Fig. 7 also shows the corresponding diagrams of the moment interactions (notations $G \cdot l \cdot \sin \varphi$ and Ω have the meaning explained in the diagrams of preceding interactions, while M is the moment of impulse pallets gravity force). We observe the pendulum swing from the left amplitude position 1, through the equilibrium position 0, as far as the position 2. The left impulse pallet is in contact with a pendulum through the impulse pin and transforms the impulse at the expense of reducing its gravitational potential energy. During that time the locking function is executed too, because one arm of the escape wheel is blocked on the locking block of the right impulse pallet. In position 2 the left impulse pallet, halted by the stop, breaks off the contact with the pendulum and terminates the impulse function. Thereafter, the pendulum, in position 3, takes and raises the right impulse pallet towards the right amplitude position 4, causing moment M to change the direction of acting. At the same time, the pendulum moves the arm of an escape wheel from the locking block (which causes a short-lived emergence of the friction force moment $\Omega!$), and by interrupting the locking function renders possible the rotation of an escape wheel and a camshaft. While the pendulum is moving together with the right impulse pallet from position 3 to 4, the escape wheel camshaft comes into contact with the left impulse pallet wedge, raises the pallet to position 6, and thus conveys some gravitational potential energy. That amount of energy will be imparted

to the pendulum afterward, during the execution of the impulse function. The rotation of the camshaft and the raise of the left pallet stop at the moment when the escape wheel arm is blocked again in contact with the locking block of the left impulse pallet. The cycle is repeated now in the second semi-cycle of pendulum oscillation, through the positions 4-0-5-6-7 → 1. The action of moments M and $G \cdot l \cdot \sin \phi$ is unilateral in sections 1-0, 3-4, 4-0 and 6-7 → 1, but in opposite direction only in sections 0-2 and 0-5, so that the tachy-chronous effect is prevailing. As a short-lived effect of the moment Ω (friction forces on the locking blocks) is unilateral with the moment $G \cdot l \cdot \sin \phi$ immediately behind the positions 3 and 6, it results that friction too, despite being slight, still contributes to tachy-chronism.

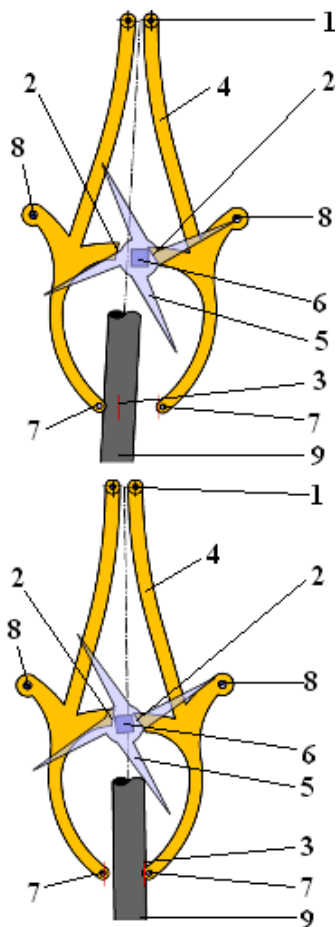

1 – Impulse pallet shaft; 2 – Impulse pallet wedge; 3 – Stop; 4 – Impulse pallets; 5 – Escape wheel arms; 6 – Camshaft; 7 – Impulse pins; 8 – Locking blocks; 9 – Pendulum

Figure 6. Denison four-legged gravity escapement

So, both moments, M and Ω , are acting integrally tachy-chronously, which means that any augmentation of the moment of impulse pallets gravity force and friction force on the locking blocks would cause diminished pendulum oscillation period and acceleration of the clock running. However, as in this case the moment M is not driving but is fully free from the influence of drive, the independence of the pendulum vibration period is safe from any alterations of driving force. Moreover, the possibility of the subtlest clock regulation results from the fact that moment M is acting tachy-chronically. To that end, sometimes spiral rods with weights are mounted on the

impulse pallets and by moving those weights their moment of mass is adjusted as well as impulse intensity, therefore the pendulum oscillation amplitudes.

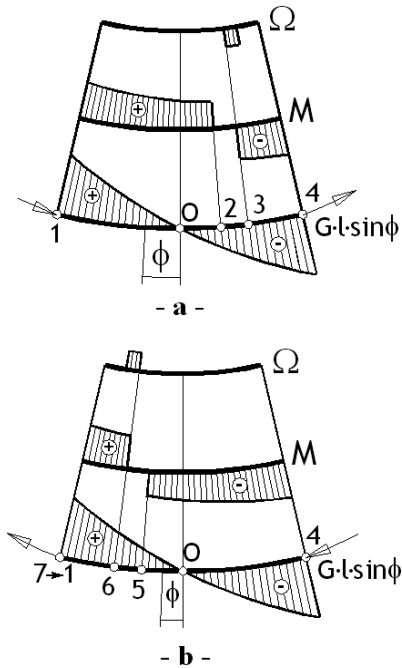

Figure 7. Diagrams of moment interactions of Denison's gravity escapements

We will also discuss briefly the horological characteristics of the so-called English and Swiss free anchor escapement and chronometer regulators, presented in Figs. 8 and 9. Careful perception of these figures can provide for readers basic principles of the considered mechanisms running. The idea is simple and common for all mechanisms: the largest portion of the engaged oscillator's oscillation period (balance wheels with pivots) is completely free from any effect of the regulator. Namely, in detached anchor escapement mechanisms balance wheels are aligned to oscillate isochronously with very large amplitude angle of $\pm 270^\circ$ and to perform balance wheel engagement with the anchor at $\pm 15^\circ$, which means that the oscillator oscillates freely longer than 88.88 % of its oscillation period duration. In chronometer regulators this ratio is even more favorable (95.5 %).



Figure 8. English and Swiss free anchor escapement

English free anchor escapement (anchor escapement with lever), characterized by toothed escape wheel, was designed by an Englishman Thomas Mudge in 1757 and improved by French horologists Abraham-Louis Bréguet, 1747-1823 and Robert Robin, 1742-1799 [4]. Swiss free anchor escapement, differing from English variant only in teeth shape of escape wheel, was designed about 1910, and due to simple building it has the most widespread use in the mechanisms of wrist and pocket watches.

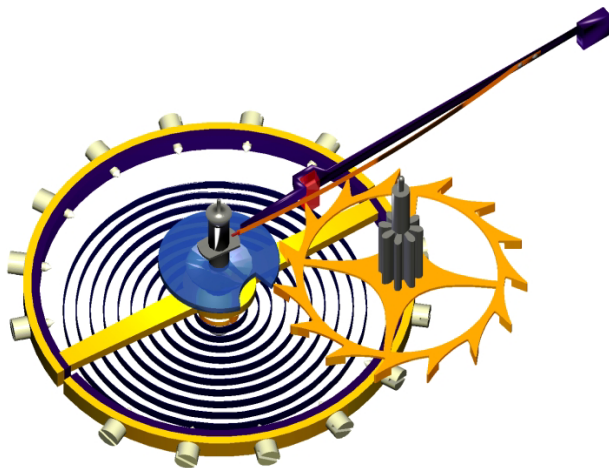

Figure 9. Chronometer escapement (T. Earnshaw)

The first chronometer escapement was built in 1748 by the French horologist Pierre Le Roy, 1717 – 1785. The mechanism was improved by English horologists John Arnold, 1736 – 1799 in 1779 and Thomas Earnshaw, 1749 – 1829, in 1783, whereby large-scale manufacturing of marine chronometers was made possible [4].

6. CONCLUDING REMARKS

As mentioned above, this work describes, over classical horological classification, the process of gradual improvement of the escapement timepiece mechanisms from the invention to this day. The following mechanisms are accentuated: the crown wheel (verge & foliot), anchor recoil, deadbeat, detached escapements, and their variations – gravity and chronometer escapements, as well as the English and Swiss lever watch escapements. All important geometrical, kinematical and dynamical properties and the influence of these properties to the clock accuracy are explained. Briefly: the analysis of kinematic and horological characteristics of each individual class of these mechanisms is reduced to basic geometry considerations, two specific functions, as well as moment interactions, of one chosen representative. After the exposed analysis, the following conclusion can be drawn and emphasized:

- Recoil and gravity escapements generate tachy-chronous and deadbeat escapement brady-chronous effects to the clock rate.
- Technical properties of clock escapement mechanisms had been gradually improved during the past centuries in such a way that level of impulse and locking function separation

increased and duration of the interaction between the escapement and the oscillator decreased. Both modifications greatly improved the clock accuracy.

- In comparison to the other escapements, the duration of the interaction between detached escapements and oscillator is decreased to the lowest level. Consequently, these escapements (gravity, chronometer, English and Swiss free anchor escapements) almost completely eliminate the influence of escapement errors to the clock rate.

All these theoretical conclusions are important not just for the horology and theory of mechanisms. They can improve the constructing and manufacturing process of various escapement mechanisms which are already known in present horological industry. Moreover, the conclusions mentioned above can be helpful in the design of new and higher quality clock and watch rate regulators.

For the sake of completeness, at the end of this paper, we find it important to mention the names of some of the ruled out mechanisms that would be the subject of future considerations due to their uncommon and valuable properties. The crown of those studies would be made up of the synthesis of the dynamic and horologically functional models [7] generated by computer graphics methodology and tools [5].

Let us start from the oldest rate regulator that was incorporated into medieval timepieces. A forgotten crown wheel and verge reappeared, engaged with the Huygens balance wheel with pivot, to regulate the rate of pocket watch mechanism. Due to its property that lubrication is not required, present in chronometer escape wheels only, a famous Grasshopper recoil escapement of John Harrison, 1693 – 1776, deserves to be mentioned among the recoil regulators. It is the escapement whose name mirrors specific motion of its pallets that Harrison, incorporating it into the first marine chronometer H1, solved the problem of longitude. From the class of detached escapements another two mechanisms are given prominence. The first is the Riefler escapement mechanism (Sigmund Riefler, Deutsches Reichs Patent, 1889) that was installed in astronomical clocks of the highest accuracy in the period 1890 – 1965. The rate error in these clocks with pendulum was less than 10 milliseconds a day! The second detached escapement is contemporary, patented in 2000 by Beat Haldimann, 1964 –) one of the most prominent horologists and timepiece-makers of the present day. Haldimann's work and inventions are the best evidence that "art, science and skill" of building mechanical clocks is not alive but is passing through its new Renaissance.

REFERENCES

- [1] Song, R.-C., Li, P., Tan, H.-M. and Shi, S.-T.: Timing dispersion of clock mechanism with parameter of escapement mechanism, Transactions of Beijing Institute of Technology, Vol. 30, No. 3, pp. 263-265, 2010.

- [2] Denny, M.: Verge and foliot clock escapement: A simple dynamical system, *The Physics Teacher*, Vol. 48, No. 6, pp. 374-376, 2010.
- [3] North, J.: *God's Clockmaker: Richard of Wallingford and the Invention of Time*, Hambledon Continuum, London, 2005.
- [4] Gazeley W.J.: *Clock and Watch Escapements*, Robert Hale, London, 1992.
- [5] Pastor, S., Obradović, R. and Kojić, M.: Combination of perpendicular oscillations and analysis of harmonograph's curves using math and CAD tools, in: *Proceedings of the 2nd International Scientific Conference – moNGeometrija 2010*, 24-27.06.2010, Belgrade, Serbia, pp. 495-508.
- [6] <http://www.clock-watch.de>
- [7] Tam, L.C., Fu, Y. and Du, R.: Virtual library of mechanical watch movements, *Computer-Aided Design & Applications*, Vol. 4, No. 1-4, pp 127-136, 2007.

ЕВОЛУЦИЈА ЗАПРЕЧНО-ИМПУЛСНИХ МЕХАНИЗАМА

**Миодраг Стоименов, Бранислав
Попконстантиновић, Љубомир Миладиновић,
Драган Петровић**

Рад приказује и објашњава конструктивне детаље еволуције запречно-импулсних механизма часовника кроз векове. Као посебно значајни, истакнути су следећи механизми: крунски точак, вретено и балансна полука, котвене запречнице са повратним трзајем, мирне, слободне, а посебно њихове подврсте – гравитационе и хронометарске запречнице, као и енглеске и швајцарске запречнице са анкером. Објашњена су сва битна геометријска, кинематска и динамичка својства побројаних група механизма, као и утицај тих својстава на равномерност хода часовника.