

# Reduced Order Model for an Electro-Hydraulic Valve of A Gas Turbine Engine's Controller

**Wael M. Elmayyah**

Department of Mechatronics  
Military Technical College  
Cairo  
Egypt

**Mostafa M. Samy**

Department of Mechatronics  
Military Technical College  
Cairo  
Egypt

*Gas turbine engines (GTE) are widely used in military and industrial applications. Accurate modeling is mandatory to advance GTE control. The present article investigates, experimentally and theoretically, a detailed dynamic model of an electro-hydraulic system that controls a variable geometry inlet guide vanes (VIGV) of turboshaft GTE. A parametric study for the computationally expensive and time-consuming model has been conducted considering the forces affecting the valve's spool and its relatively short settling time. A reduced mathematical model has been developed. The prediction results of the reduced and full-detailed models have been compared with the experimental results. The reduced model has decreased calculation time by 45% to 50 % while keeping the RMSE of the model within 1-2 % away from the actual system's experimental results for the complete operating range. An improvement allows future studies to integrate the whole subsystems of the GTE in a single computationally affordable model.*

**Keywords:** Gas Turbine Engine, modeling, electro-hydraulic valve.

## 1. INTRODUCTION

The performance of an industrial turboshaft gas turbine engine relies on controlling three main parameters: main fuel flow (MFF), power turbine stator angle (PTS), and VIGV angle. The engine under study consequently has three subsystems to facilitate and ensure precise engine control. The main fuel flow circuit controls the fuel metering valve to regulate the inlet fuel flow rate to the combustion chamber. The PTS and the VIGV have two separate electro-hydraulic control circuits; however, they are identical in construction and operation except for the final actuator and vanes tilting mechanism. Both use the fuel as a power fluid and have identical electro-hydraulic servo valves driven by a proportional solenoid. The three subsystems are integrated into a single hydraulic management unit (HMU), as Figure 1 (left) illustrates.

This study is part of a research program to develop a complete engine model. The gas turbine engine under investigation is used for ground vehicles. The electro-hydraulic system has been investigated as a main part of the engine controller. The hydraulic system has sophisticated flow behavior due to tiny clearance and orifices. The physics-based model for such a system requires many differential equations. One of the most challenging problems in electro-hydraulic control systems is modeling the non-linearity of fluid behavior due to specially shaped orifices and unmeasurable parameters such as discharge coefficient and in-valve fluid damping coefficient.

Presenting a dependable and accurate model for the electro-hydraulic position control system incorporated

in GTEs is fundamental to understanding dynamics before studying or developing the Engine controller. Although these electro-hydraulic position control systems are widely used in aviation and non-aviation GTEs, most published studies still need to treat modeling such systems thoroughly. A few studies have provided detailed physics-based models. Still, they have tended to focus on the electro-hydraulic subsystem behavior rather than its role in the complete model of GTE.

Many researchers have investigated and modeled electro-hydraulic systems for performance enhancement by applying different control approaches. For example, Yang et al. [1] developed a model reference adaptive control (MRAC) based on neural networks to control a hydraulic cylinder, while Sadeghieh et al. [2] went for neurobiology to control a rotary actuator. To design networked control systems using the modified generalized predictive control (M-GPC) method, Yu et al. [3] applied this method to a hydraulic positioning system. Another method Bravo et al. [4] uses is Embedded Model Control. Lai et al. [5] applied a fuzzy pulse width modulation (PWM) technique to achieve higher position control accuracy. In the same context, Ye et al. [6] adopted an improved particle swarm optimization (PSO) to optimize a PID Position controller of a non-linear hydraulic system. These studies relied on a dynamic mathematical model; therefore, any enhancement or simplification in the mathematical model would lead to less computational effort and faster real-time response.

On the other hand, various approaches have been adopted to model the electro-hydraulic position systems; These studies went from the physical model equations to the system identification or using both to overcome the non-linearity or simplify the model. For example, Puller et al. [7] physically derived a non-linear model for an electro-hydraulic servo system of GTE's variable stator vanes.

Received: November 2022, Accepted: March 2023

Correspondence to: Dr Wael M. Elmayyah

Department of Mechatronics,  
Military Technical College, Cairo, Egypt

E-mail: wael.elmayyah@mtc.edu.eg

doi: 10.5937/fme2302169E

© Faculty of Mechanical Engineering, Belgrade. All rights reserved

FME Transactions (2023) 51, 169-175 169

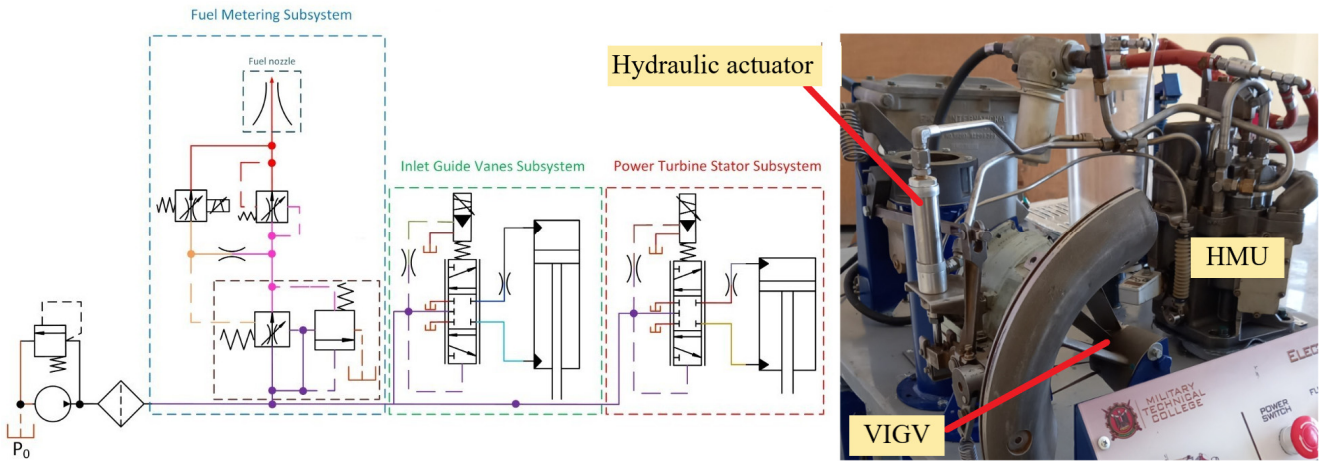

Figure 1. Illustration of the hydraulic management unit (left), experimental setup (right)

Then they simplified it into a linear one disregarding the main hydraulic behavior of the system to suit the purpose of controller optimization. Yan et al. [8] built a state space non-linear model, simplified it into a linear-in-parameters structure, compared its tracking performance to independent Hammerstein, Wiener, and ARX models, and showed significant improvement but yet not sufficient for controller development. At the same time, Liu et al. [9] presented a proportional electro-hydraulic valve's multi-domain state space non-linear model considering the electromagnetic, mechanical, and hydraulic subsystems. They justified the 15% deviation of their model simulation from the actual measured response because of unknown parameters and parameter measurement errors. Another model-based control technique via sliding mode control was proposed by Zou et al. [10] by simplified dynamic modeling for an electro-hydraulic servo system, not considering the non-linearity of fluid behavior. In the same vein, Shen et al. [11] designed a position control scheme combined with an extended state observer (ESO) based on an electro-hydraulic position servo-mechanism simplified model. The challenge in modeling fluid power systems is not limited to pure hydraulic systems. Still, it extends to

hybrid electro-hydraulic and pneumatic systems by Hoang et al. [12], presenting a dynamic model for high-performance tracking control of rapidly changing acceleration. Many other researchers [13-19] modeled the electrohydraulic control system of gas turbine engines. Additionally, in some recent literature, other studies [20-22] have considered modeling the same electro-hydraulic systems yet utilized in other applications.

Samy et al. [24] developed a fully detailed model for the electro-hydraulic system: a position control circuit. The system controls the engine's air inlet guide vanes (VIGV) position utilizing a linear hydraulic double-acting cylinder controlled via an electrohydraulic directional control valve. A test rig was built by Samy et al. [24] to facilitate measuring the actual system response and controlling it. A dynamic mathematical model was derived and solved by SIMULINK. The Predicted results of the mathematical model were compared with the experimentally measured results. The comparison showed that the most extreme difference between the measured and predicted results was less than 5%. Therefore, the presented model could be used for further development.

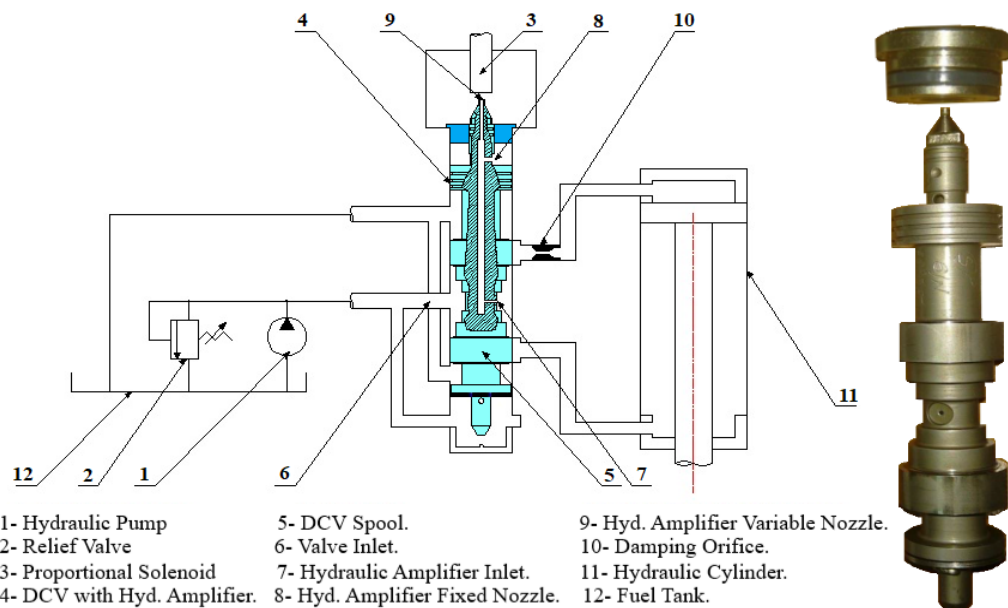

Figure 2. Hydraulic Circuit Scheme (left), the spool of the servo-valve (right)

However, all of the studies mentioned above suffered from some serious shortcomings stemming from at least one of the following: None of them took into consideration the sophisticated fluid's behavior incorporated in the system and its influence on the overall response, nor the effect of simplifying the model to the prediction accuracy and solving time. Therefore, the present study fills this gap in the literature by providing important insights into model order reduction while keeping an eye on the model's accuracy.

In this study, a complete dynamic model approach will be considered to model the system. To validate the model, it will be compared to the real system behavior, measured from the experimental setup shown in Figure 1 (right). The main practical application of this system is the hydraulic management unit (HMU) utilized in a 1500 HP double-spool turboshaft GTE. The specific objective of this study is to build a dependable mathematical model for the electrohydraulic control of the VIGV to predict the system's behavior.

## 2. MATHEMATICAL MODEL

A detailed mathematical model has been developed by [24] to simulate and predict the electrohydraulic system behavior. The details and complete mathematical equations were essential as a first step in investigating the system. However, the detailed model requires a huge computational effort. This effort would be increased dramatically if the three subsystems and the whole GTE were modeled. Therefore, reducing the VIGV electrohydraulic system model will significantly reduce the computational cost of the controller model and open the way for further simplification and reduction. Figure 2 shows the construction of the control valve side by side with a photo of the real valve's spool. The model describes the electromagnetic and dynamic behavior of the proportional solenoid, the hydraulic amplifier flow and continuity equations, and the valve's spool equation of motion. The proportional solenoid's model consists of 6 equations, while the electro-hydraulic valve's model consists of 20.

The experimental results have validated the predicted results. To investigate the mathematical model, Figure 3 and Figure 4, adopted from [24], show the predicted and experimental results (actuator displacement) of the real electro-hydraulic system and the system's model when excited with 4 VDC (as a retraction signal) and 7 VDC (as an extension signal) correspondingly.

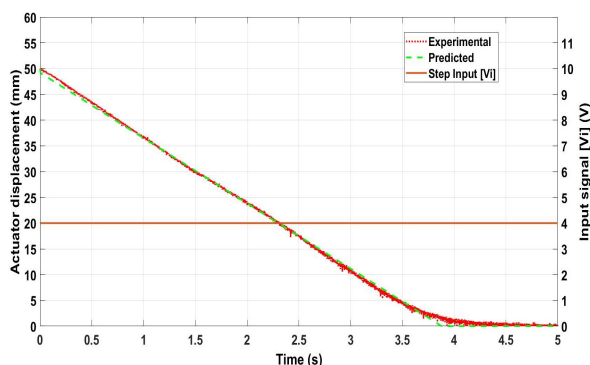

Figure 3. The predicted and experimental actuator retraction displacement at input 4V

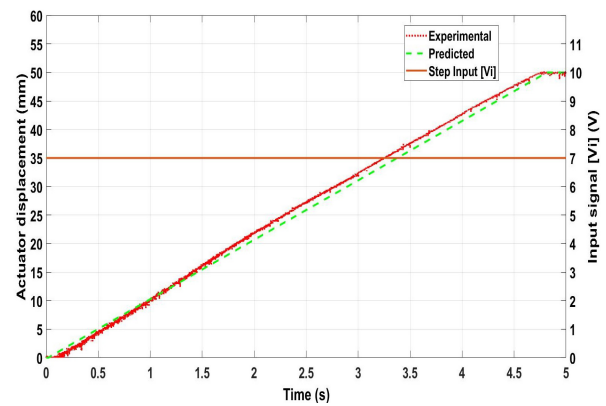

Figure 4. The predicted and experimental actuator extension displacement at input 7V

Even though the comparison results showed a significant correlation, we still need to study the forces' effect on the spool to simplify the mathematical model or improve it further. This complicated mathematical model should be integrated with additional subsystems to model the full electro-hydraulic control system mathematically.

### 2.1 Forces acting on the spool analysis

In this section, the forces acting on the servo valve spool are investigated to evaluate the impact of the computational cost of the complicated model on its accuracy. According to Equation (1), the equation of motion of the valve's spool, the net force affecting it results from the pressure, friction, spool's weight, jet reaction, and seat damping forces. This last force is the reaction of the valve's sleeve on the spool body when it reaches the end of its stroke on either side and has no effect over its normal operating range. It can be calculated assuming a stiffness and a damping coefficient for the sleeve's body [25]. On the other hand, the pressure force results from the effect of the supply pressure on the spool's bottom side's area and the hydraulic-servo amplifier pressure on the spool's upper side's area, which makes the pressure force the most significant one among the others. Also, the friction force results from the mechanical friction between the spool and the sleeve's wall and the hydraulic friction due to the fluid's viscosity. The friction force is calculated by multiplying the damping coefficient and the spool's velocity.

Consequently, it is proportional to the spool movement speed, greatly affecting its displacement. The weight, in this case, is also considered because of the vertical orientation of the valve and, correspondingly, its spool. Finally, the jet reaction force is the momentum rate of change of the fluid due to fluid flow. It can be obtained by getting the ratio of the fluid's squared flow rate through the valve's port times its density ( $\rho * Q^2$ ) to the flow effective area ( $C_c * A$ ) [25]. The relatively low flow rates across the valve's ports reduce the jet reaction force.

$$m_s \times \ddot{x}_s = F_p - F_f - f_{seat} - F_j - W_s \quad (1)$$

The valve's dynamics have been modeled using MATLAB-Simulink. The valve response at various in-

put signals has been simulated. Simulink® solver ODE3 (Bogacki-Shampine) continuous explicit solver with a step size of  $(10^{-5} \text{ s})$  and preset solving accuracy of (0.001) was used to solve the model's differential equations. The forces acting on the valve's spool have been graphically represented to illustrate the effect of each force on the valve, along with the overall effect of spool forces on the system output. Figure 5 and Figure 7 shows the simulation results for the spool forces in retraction stroke responding to a step input of 4 V and 0 V correspondingly. While Figure 6 and Figure 8 shows the simulation results for the spool forces in extension stroke responding to a step input of 7 V and 11 V correspondingly. For each figure, the x-axis is the response time in seconds, the left y-axis for the acting forces in newtons, and the right y-axis for the spool and the solenoid displacement in millimeters.

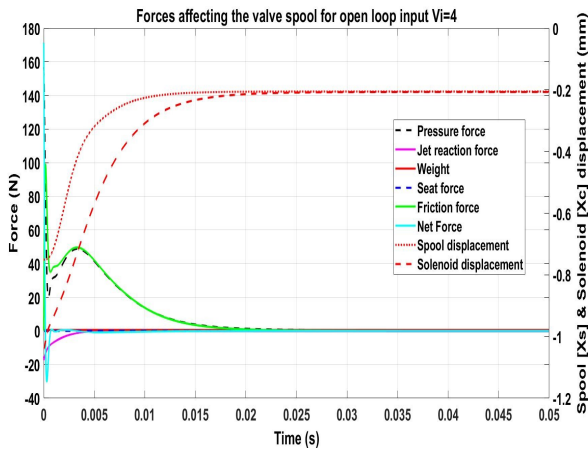

Figure 5. Forces acting on the valve's spool at 4V

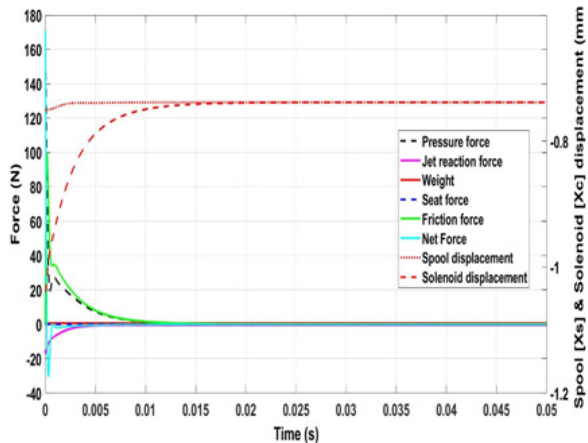

Figure 6. Forces acting on the valve's spool at 0 V

Both retraction figures show that the transient time the valve's spool and solenoid take to reach its steady state position is less than 15 ms. At the same time, it takes less than 20 ms for the valve's spool and solenoid to reach their steady-state position in both extension figures. To introduce an explanation: The reason the spool was faster settled in retraction was obvious: the effect of the spool's weight acting downward, therefore accelerating the spool in retraction.

The whole four figures of both extension and retraction also showed the following:

- The most significant forces on the spool are the pressure, friction, and weight forces.

- There is an insignificant effect of the spool displacement from the jet or seat force.

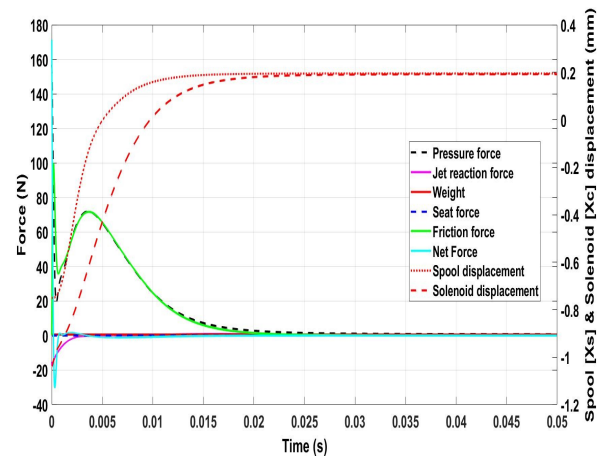

Figure 7. Forces acting on the valve's spool at 7V

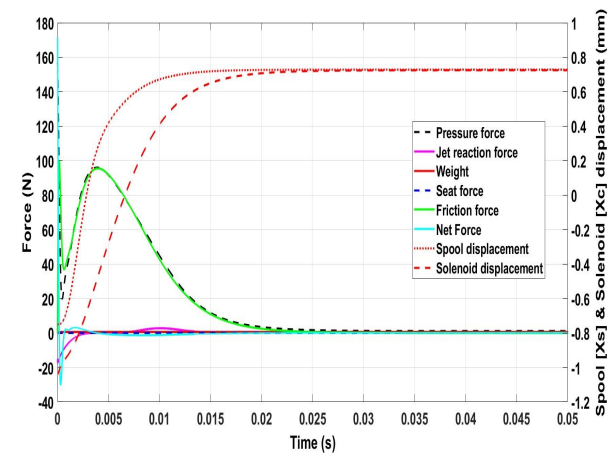

Figure 8. Forces acting on the valve's spool at 11 V

## 2.2 Reduced model simplification

A comparison has been made between the spool's response, shown in Figure 5 & Figure 6, and the actuator's displacement, shown in Figure 3 & Figure 4, correspondingly. It is worth noting here that the comparison revealed, as clarified in Table 1, that the percentage of the spool's settling time to the actuator's settling time ranged from 0.43% to 1.47%. Therefore, the transient response of the spool can be considered insignificant to the actuator's dynamic response.

The most prominent finding from the previous analysis is that the model under study can be simplified by neglecting the effect of the jet and seat forces on the spool in case of studying the valve's internal behavior. The spool displacement that leads to a certain volume flow rate could be calculated in a simple equation assuming quasi-steady flow. This could simplify the spool's equation of motion here to only:

$$m_s \times x_s'' = F_p - F_f - W_s \quad (2)$$

In addition, the model can be simplified even more to predict the electrohydraulic actuator's displacement. It is possible, therefore, that spool displacement can be directly predicted at every input voltage value as a linear function of the input voltage, as presented in Fig. 9.



**Table 1. Comparison between the rise time for the displacement of Solenoid, Spool, and Actuator**

Inlet Volt	Solenoid disp. rise time (s)	Spool disp. rise time (s)	Actuator disp. rise time (s)	<i>Spool rise time</i> / <i>Actuator rise time</i> (%)
0	0.015	0.005	1.7	0.3
4	0.02	0.015	3.85	0.4
7	0.02	0.015	4.7	0.3
11	0.02	0.015	1.8	0.8

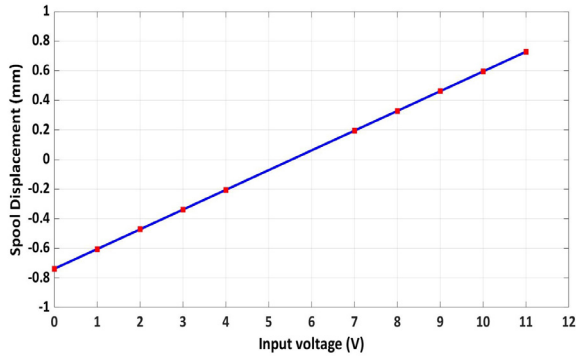

**Figure 9. shows the spool displacement as a linear function of the input voltage**

The figure shows that the spool displacement - input voltage relation is almost linear. This finding and the insignificant transient response of the spool could encourage the following simplification: replacing the second-order valve's spool equations with a linear equation between the solenoid's input voltage and the spool's displacement, assuming quasi-steady flow. Thus, Equation (3) is suggested  $X_s = 0.10333 * V_i - 0.7348$

to replace the solenoid equations, the hydraulic amplifier equation, and the spool's equation of motion in the full detail model.

$$X_s = 0.10333 * V_i - 0.7348 \quad (3)$$

### 2.3 Reduced model simulation

They are moving on now to modeling and simulating the reduced model with MATLAB-Simulink. The valve response was obtained using the previously mentioned solver settings for retraction and extension strokes at different input signals covering the whole operating range from 0 VDC to 11 VDC. It is noteworthy to mention that input signals less than 5.5 DCV cause actuator retraction, while actuator extension results from greater input signals. The predicted results for the reduced model have been compared with the full model simulation and the experimental results when excited with 4 VDC (as a retraction signal) and 11 VDC (as an extension signal) to evaluate the reduced model. Figure 10 and Figure 11 shows experimental results (red dotted curve) of the real electro-hydraulic system along with the predicted result of both the reduced (green dashed curve) and the full models (black curve) for retraction and extension strokes correspondingly.

For each figure, the x-axis is the response time in seconds, the left y-axis is for the actuator displacement in millimeters, and the right y-axis is for the voltage input signal. Both figures demonstrate how close is the

reduced model's response to the full model. In addition, a comparison between the RMSE corresponding to the reduced model prediction and, thus, of the full model prediction took place to evaluate the model accuracy.

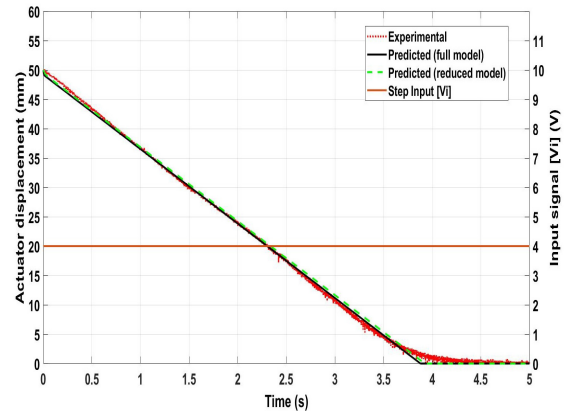

**Figure 10. Reduced Model vs. Full Model & Experimental at 4V input**

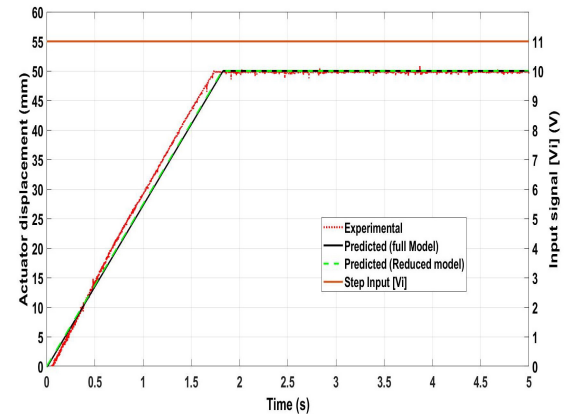

**Figure 11. Reduced Model vs. Full Model & Experimental at 11V input**

## 3. RESULTS

In this section, the results of the reduced model's simulation explained in the previous section will consider two aspects:

- Model accuracy by evaluating RMSE of the reduced and full models.
- Model solving time or, in other words, the computational cost of solving the model.

Table 2 compares the RMSE of the reduced and the full models at different input signals covering the whole operating range. The comparison proves that the reduced model has the same accuracy as the full model at most of the input signals, and at some particular inputs, the error increases by 1%. Therefore, from the accuracy point of view, the full model is more accurate at some input signals. This tiny advantage can only be meaningful by evaluating its computational cost.

To determine how much reducing the model affects its computational cost, the full and the reduced models have been processed on two different machines using the same release of Simulink. The first processor is OMEN I7 with 32G RAM; the second is ThinkPad I7 with 8G RAM. The two processors solved both models for the whole operating range input signals.

**Table 2 Root Mean Square Error of Piston Displacement**

Input Volt (V)	0	1	2	3	4	7	8	9	10	11
Full Model RMSE [%]	1	1	1	1	1	1	1	1	1	1
Reduced Model RMSE [%]	1	2	1	2	1	2	1	1	1	2

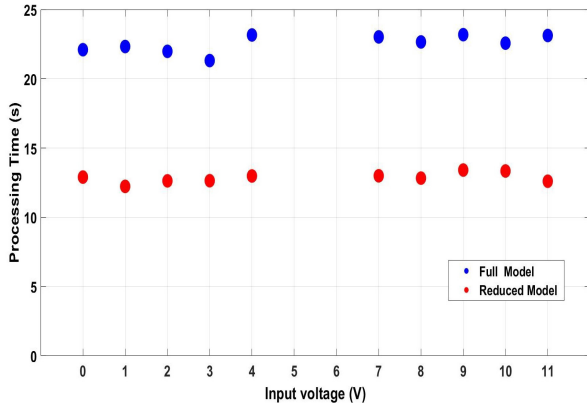
**Figure 12. Models Processing Time**

The reduced model's solving time is less than the full model for all signals at both processors. The processing time of the full and the reduced model at the first processor is shown in Figure 12. The results show that the reduced model could reduce the processing time by 40% to 60%.

#### 4. CONCLUSIONS

The full mathematical model of the VIGV hydraulic system position control has been investigated theoretically and experimentally. The experimental and the simulation results led to the following findings:

- In the case of studying the valve's internal behavior, the model can be reduced by neglecting the jet and seat forces on the spool due to their insignificant effect.
- In the case of utilizing the model to predict the electrohydraulic actuator's displacement, the transient response of the spool founded to be insignificant, and the model was reduced by replacing multiple second-order equations that describe the solenoid's electromagnetic behavior, the hydraulic amplifier flow equation, continuity equations, and equation of motion into only one linear equation.
- The Reduced model has reduced calculation time by a percent ranging from 45% to 50 % while keeping the RMSE of the model within just 1-2 % away of the actual system's experimental results for the complete operating range. The such improvement allows future studies to integrate the whole subsystems of the GTE in a single computationally affordable model.

#### REFERENCES

[1] Yang, Y., Balakrishnan, S. N., Tang, L., and Landers, R. G., 2011, "Electro-hydraulic piston control using neural MRAC based on a modified

state observer," In Proceedings of the 2011 American Control Conference, IEEE.

- [2] Sadeghieh, A., Sazgar, H., Goodarzi, K., and Lucas, C., 2012, "Identification and real-time position control of a servo-hydraulic rotary actuator by means of a neurobiologically motivated algorithm," *ISA Transactions*, 51(1), Jan, pp. 208–219.
- [3] Yu, B., Shi, Y., and Huang, J., 2011, "Modified generalized predictive control of networked systems with application to a hydraulic position control system," *Journal of Dynamic Systems, Measurement, and Control*, 133(3), mar.
- [4] Acunna-Bravo, W., Ma, Y., and Canuto, E., 2015, "Position control of proportional electrohydraulic valves: An embedded model control solution," In 2015 34th Chinese Control Conference (CCC), IEEE.
- [5] Lai, W. Y., Onn, N., Tang, C. H. H., and Hussein, M., 2015, "Position control of hydraulic actuators using fuzzy pulse width modulation (PWM)," *Applied Mechanics and Materials*, 735, Feb, pp. 294–298.
- [6] Ye, Y., Yin, C.-B., Gong, Y., and Jing Zhou, J., 2017, "Position control of non-linear hydraulic system using an improved PSO based PID controller," *Mechanical Systems and Signal Processing*, 83, Jan, pp. 241–259.
- [7] Puller, T., and Lecchini-Visintini, A., 2016, "Modelling for control of a jet engine compressor variable stator vanes hydraulic actuator," In 2016 European Control Conference (ECC), IEEE.
- [8] Yan, J., Li, B., Ling, H.-F., Chen, H.-S., and Zhang, M.-J., 2013, "Non-linear state space modeling and system identification for electrohydraulic control," *Mathematical Problems in Engineering*, 2013, pp. 1–9.
- [9] Fang Liu, Y., Kun Dai, Z., Yang Xu, X., and Tian, L., 2011, "Multi-domain modeling and simulation of proportional solenoid valve," *Journal of Central South University*, 18(5), Oct, pp. 1589–1594.
- [10] Q. Zou, "Extended state observer-based finite time control of electro-hydraulic system via sliding mode technique," *Asian J Control*, vol. 24, no. 5, pp. 2311–2327, Sep. 2022, doi: 10.1002/ASJC.2638
- [11] Shen, W., and Shen, C., 2021, "An extended state observer-based control design for electrohydraulic position servo-mechanism," *Control Engineering Practice*, 109, Apr, p. 104730.
- [12] Hoang, Q.-D., Lee, S.-G., and Dugarjav, B., 2018, "Super-twisting observer-based integral sliding mode control for tracking the rapid acceleration of a piston in a hybrid electro-hydraulic and pneumatic system," *Asian Journal of Control*, 21(1), Dec, pp. 483–498.
- [13] Kumarin, A., Kuznetsov, A., and Makaryants, G., 2018, "Hardware-in-the-loop neuro-based simulation for testing gas turbine engine control system," In 2018 Global Fluid Power Society PhD Symposium (GFPS), IEEE.

- [14] Taghizadeh, M., Ghaffari, A., and Najafi, F., 2009, "Modeling and identification of a solenoid valve for PWM control applications," *Comptes Rendus Mecanique*, 337(3), Mar, pp. 131–140.
- [15] Lee, J.-H., Yun, Y.-W., Hong, H.-W., and Park, M.-K., 2015, "Control of spool position of on/off solenoid operated hydraulic valve by sliding-mode controller," *Journal of Mechanical Science and Technology*, 29(12), Dec, pp. 5395–5408.
- [16] Cheung, N., Lim, K., and Rahman, M. "Modelling a linear and limited travel solenoid," In *Proceedings of IECON '93 - 19th Annual Conference of IEEE Industrial Electronics*, IEEE.
- [17] Zavarehi, M. K., Lawrence, P., and Sassani, F., 1999, "Non-linear modeling and validation of solenoid-controlled pilot-operated servovalves," *IEEE/ASME Transactions on Mechatronics*, 4(3), pp. 324–334.
- [18] Othman, S.M. et al. "Optimization of Modified Sliding Mode Controller for an Electro-hydraulic Actuator system with Mismatched Disturbance." *International Journal of Electrical and Computer Engineering* 8, no. 4 (2018): 2148-2156.
- [19] Wang, C., Li, Y., and Yang, B., 2017, "Transient performance simulation of aircraft engine integrated with fuel and control systems," *Applied Thermal Engineering*, 114, mar, pp. 1029– 1037.
- [20] E. E. Ibrahim, T. Elnady, M. S. Hassan, and I. Saleh, "Modelling, transient response and hydraulic behaviour of 2DOF stabilization platform," *FME Transactions*, vol. 48, no. 4, pp. 833-840, 2020, doi: 10.5937/fme2004833E.
- [21] A. N. Aborobaa, K. A. Ghamry, A. Saleh, and M. H. Mabrouk, "Sensorless position estimating and transition time identifying for the spool of a high speed on/off solenoid valve," *FME Transactions*, vol. 50, no. 1, pp. 99–108, 2022, doi: 10.5937/FME2201099A.
- [22] A. N. Aborobaa, K. A. Ghamry, A. Saleh, and M. H. Mabrouk, "Energy-saving and performance-enhancing of a high speed on/off solenoid valve," *FME Transactions*, vol. 50, no. 2, pp. 283–293, 2022, doi: 10.5937/FME2201283A.
- [23] S. K. Suman, A. Kumar, "Reduced order modelling and balancing control of bicycle robot," *FME Transactions*, vol. 49, no. 4, pp. 919–934, 2021, doi: 10.5937/FME2104919K.
- [24] Samy, M., Metwally, M., Elmayyah, W., and Elsharif, I., 2017-04, "Investigation of electrohydraulic control of a gas turbine engine's inlet guide vanes," *International Conference on Aerospace Sciences and Aviation Technology, ASAT, 17 (AEROSPACE SCIENCES)*, pp. 1– 10.
- [25] M. G. El-Din and M. Rabi, *Fluid Power Engineering*. McGraw-Hill Education, 2009.

## NOMENCLATURE

A Valve's port area [m<sup>2</sup>]

$C_c$	Contraction coefficient	[-]
$F_f$	Friction force	[N]
$F_j$	Jet reaction force	[N]
$F_p$	Pressure force	[N]
$f_{seat}$	Seat reaction force	[N]
$m_s$	Spool mass	[Kg]
$Q$	Fluid volumetric flow rate	[m <sup>3</sup> /s]
$V_i$	Solenoid input voltage	[V]
$W_s$	Spool weight	[N]
$x_s$	Spool displacement	[m]
$\dot{x}_s$	Spool speed	[m/s]
$\ddot{x}_s$	Spool acceleration	[m/s <sup>2</sup> ]
$\rho$	Fluid density	[Kg/m <sup>3</sup> ]

## ACRONYMS

ARX	Autoregressive with exogenous variables
ESO	Extended State Observer
GTE	Gas Turbine Engine
HMU	Hydraulic Management Unit
HP	Horse Power
MFF	Main Fuel Flow
M-GPC	Modified Generalized Predictive Control
MRAC	Model Reference Adaptive Control
PID	Proportional Integral Derivative
PSO	Particle Swarm Optimization
PTS	Power Turbine Stator
PWM	Pulse Width Modulation
RMSE	Root Mean Square Error
VDC	Volts of Direct Current
VIGV	Variable Inlet Guide Vanes

## МОДЕЛ СМАЊЕНЕ ПОРУЏБИНЕ ЗА ЕЛЕКТРО-ХИДРАУЛИЧНИ ВЕНТИЛ КОНТРОЛЕРА ГАСНОТУРБИНСКОГ МОТОРА

В.М. Елмајах, М.М. Сами

Гаснотурбински мотори (ГТЕ) се широко користе у војним и индустријским апликацијама. Прецизно моделирање је обавезно за унапређење ГТЕ контроле. Овај чланак истражује, експериментално и теоријски, детаљан динамички модел електрохидрауличког система који контролише улазне лопатице променљиве геометрије (ВИГВ) турбовратила ГТЕ. Спроведена је параметарска студија за рачунарски скуп и дуготрајан модел узимајући у обзир силе које утичу на калем вентила и његово релативно кратко време таложења. Развијен је редуковани математички модел. Резултати предвиђања редукованих и потпуно детаљних модела упоређени су са експерименталним резултатима. Смањени модел је смањео време израчунавања за 45% до 50% док је РМСЕ модела задржао на удаљености од 1-2% од експерименталних резултата стварног система за комплетан радни опсег. Побољшање омогућава будућим студијама да интегришу читаве подсистеме ГТЕ у један рачунарски приступачан модел.