

Krešimir Osman

Lecturer
Department of Electrical Engineering
Zagreb University of Applied Sciences
Zagreb
Croatia

Andrija Topčić

Electrical Engineer
Aeroteh d.o.o.
Zagreb
Croatia

Mato Perić

Assistant Professor
Department of Mechanical Engineering
University North
Koprivnica
Croatia

Dragi Stamenković

Professor
The College of Applied Studies "Aviation
Academy"
Belgrade
Serbia

Presentation of Control Algorithm for Cooling System in Business Building

This paper presents an algorithm for controlling and monitoring a cooling system in a business building by using the human-machine interface (HMI). The computer program for automatic control was implemented by using the ©SIEMENS TIA portal computer program. Based on the previously created hydraulic schema of the system, a ladder diagram was created, which was stored in the PLC with the aim of further automatic system control. In addition, a SCADA system was implemented to monitor all the processes of the cooling system under consideration. The control system is designed as a remote-control system with the possibility of adjusting and monitoring the system from a remote location via a computer or mobile device.

Keywords: cooling system, control algorithm, remote-control system, PLC, SCADA, HMI

1. INTRODUCTION

Living standards of human society [1] can be expressed in terms of energy consumption. This standard rises with increasing energy consumption. Since a large proportion of working time is spent indoors, automatic control and developing modern control algorithms for heating, ventilation, and cooling systems are essential. It has been proven that parameters in enclosed spaces, such as pressure, temperature, and humidity, strongly influence human productivity. The aim of an automatic control system [2] is to achieve the highest possible system efficiency with the lowest possible energy consumption. In addition, the aim is to protect the environment as much as possible, and great importance is attached to raising citizens' ecological awareness and promoting the concept of sustainable development. Also, this type of control aims to control and access all the devices in the system's field of observation from a central point. In this type of control, the system is used as a whole, made up of a series of interconnected elements that ensure its proper, efficient, and safe functioning. It also aims to replace humans in process control, making it more reliable and accurate. Today's automatic control manufacturers have been keeping up with the times [3], introducing and applying new technologies to achieve the best functionality and efficiency of the system, system quality, and cost price. Nowadays, electricity is the preferred energy source [4]. The reason for this is that it is a clean source that is increasingly obtained from renewable energy sources. This type of system lowers the price of electricity and is more stable on the market compared to other energy sources.

The paper shows the performance of the control algorithm by using a programmable logic controller (PLC) and Supervisory Control and Data Acquisition (SCADA) monitoring system to automatically control the primary part of the system in steel plants to prepare and maintain the temperature of the coolant.

2. LITERATURE REVIEW

This section presents some recent work relevant to the field.

Góra et al. [5] show a control system that has implemented all control functions for the production phase and for the regeneration of ion filter sheets. An analysis of the control devices based on a simple logic PLC control is presented.

The paper of Bayindir and Cetinceviz [6] describes a water pumping control system. The system uses programmable logic controllers (PLC) and industrial wireless local area network (IWLAN) technology. The work aims to propose a suitable solution in process plants where cabling is impossible.

Morsi and El-Din's [7] paper shows the implementation and application of PLC and SCADA systems in a system to control oil refinery processes automatically. This research resulted in no waste of manpower and material resources and increased the workers' safety in the system.

Carvajal et al. [8] show the implementation and application of PLC and SCADA systems in a system to control oil refinery processes automatically. This resulted in no waste of manpower and material resources and increased the workers' safety in the system.

The paper of Farval et al. [9] presents an automation system of protection system components in the power grid at a laboratory level by using a programmable logic controller (PLC) in combination with a monitoring, control, and data acquisition system (SCADA). It enables intelligent decision-making, reading, activation, monitoring, and maintenance of records on the computer.

Received: December 2023, Accepted: February 2024
Correspondence to: Krešimir Osman, Zagreb University of Applied Sciences, Department of Electrical Engineering, Konavoska 2, 10000 Zagreb, Croatia
E-mail: kresimir.osman@tvz.hr
doi: 10.5937/fme2402206O

© Faculty of Mechanical Engineering, Belgrade. All rights reserved

FME Transactions (2024) 52, 206-213 **206**

Rashad et al. [10] present the system of a programmable logic controller (PLC) and human-machine interface (HMI) in a SCADA system with built-in machine learning classifiers. The system was designed to control and monitor a petroleum products terminal automatically.

Məmmədli and Kabaoğlu [11] show the application of 3 types of PLCs: S7-300, S7-1200, S7-1500, and Arduino in combination with the MODBUS protocol. In addition, the SCADA monitoring system was used to detect errors in the system early and intervene quickly. The system for the synchronous operation of a spring bending machine stepper and servo motors was controlled.

With the aim of controlling the heat transfer, the model of the self-regulating temperature cascade of the reactor plant was developed by Shoga et al. [12] in conjunction with the model of the material and energy balance of the exothermic stirred reactor. The MATLAB Simulink program implements the control system to carry out the plant simulation.

The paper of Osman et al. [13, 14] presents research work on the development and implementation of a control system in a smart building. For this purpose, two approaches were selected and presented together with the simulation results obtained. The first approach is theoretical in nature, using the computer program ©MATLAB Simulink. Another experimental approach is implementing a remote-control system developed with the ©Siemens TIA Portal software tool. A heating and domestic hot water system in a detached house with three residential units was chosen as the case study.

The contribution of this paper is as follows:

- The control system with a PLC controller and SCADA system has an implemented PID algorithm. It is controlled with electric actuators on the elements in the field (dampers and three-way valves). The parameters of the PID controller are set automatically via a separate subprogram in the system.
- The control system has the option of switching the operating modes from the standard cooling method to the dry cooling method and vice versa. This can be done manually or automatically.

This can be done manually or automatically.

- The system can be controlled with a remote control and monitored via a computer or mobile device from another location.

3. DESCRIPTION OF EXISTING COOLING SYSTEM

According to the presented hydraulic scheme, the cooling system under consideration (Figure 1.) contains a primary and a secondary cooling circuit so that cooling can take place all year round, even under outdoor conditions, when the ambient temperature falls below zero. A mixture of mediums such as ethylene glycol (35 %) and water (65 %) are used in the primary circuit, which enables the system to operate all year round, as this medium allows for smooth operation even at low ambient temperatures T_{amb} (down to -21°C). The system under observation was built in northern Germany. The system includes a chiller with an air-cooled condenser from the company "TRANE", type RTAF 125 XE SN, with a cooling capacity of $Q_{cool} = 747.98 \text{ kW}$, which enables a working medium temperature regime of $25/31.3^{\circ}\text{C}$. This allows for a summer operation of existing dry coolers from the company "GEA", type Har-teel Isorapid 22. The primary circuit also contains a vertical tank for the working medium with a volume of 3 m^3 , which allows for a chiller to operate with a minimum media flow rate. The primary and secondary circuits of the cooling system are separated by a plate heat exchanger, product "Alfa Laval", type T20-PFG, heat output $Q = 700 \text{ kW}$. The secondary circuit uses the working medium Ferroquench WR 10 % and operates in the required temperature range of $32/30^{\circ}\text{C}$. The temperature regime on the primary and secondary sides of the plate heat exchanger is ensured by a three-way valve with an electric actuator and associated automatic control elements (temperature and pressure sensors). The return pipeline of this primary circuit is equipped with a device for pressurization, expansion, degassing, and venting of the system in a closed cooling system product "AIR SEP", type AS-E 100/4 M with a medium tank.

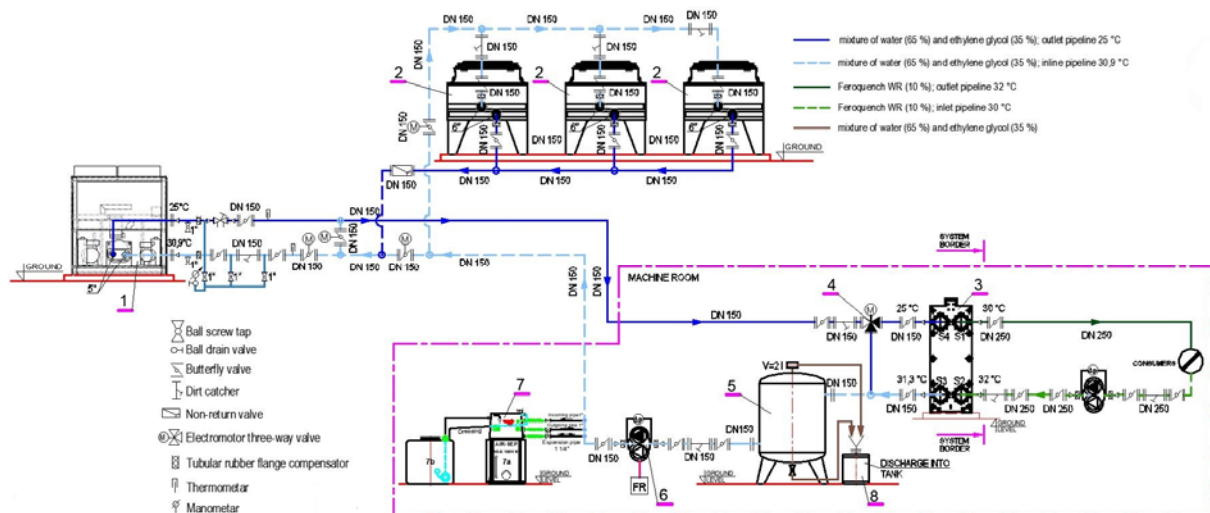

LEGEND:

- 1- AIR COOLED CHILLER "TRANE" TYPE RTAF 125 XE SN
 $Q_{cool}=747,98$ kW (25/31,3°C); $T_{amb}=35^{\circ}\text{C}$
 $N_{cool}=184,30$ kW
 $V=112$ m³/h
 400 V/3/150 Hz
 $dim. l \times w \times h=5645 \times 2200 \times 2526$ mm
 $m=3800$ kg
- 2- DRY COOLER "GEA TIP HARTEOEL ISORAPID 221 (kom. 3)
 $Q=233,33$ kW ($t_w=31,3/25^{\circ}\text{C}$)
 $V=37,33$ m³/h
 $\Delta p=70000$ kPa
- 3- PLATE HEAT EXCHANGER "ALFA LAVAL"
 TYPE T20-PFG
 $Q=700$ kW
 PRIMARY: MIXTURE OF WATER AND ETHYLENE GLYCOL (35%); 25/31,3 °C
 SECONDARY: FERROQUENCH (10 %); 32/30 °C
- 4- THREE WAY VALVE WITH ELECTRIC MOTOR DRIVE
 "SIEMENS" VXF 42.150-315; $k_v=315$; $dp_{100}=12$ kPa; $V=112$ m³/h
 "SIEMENS" SKC 60 (AC 24 V, 0-10 V)
- 5- FLOW TANK OF A MIXTURE OF WATER AND ETHYLENE GLYCOL (BUFFER), "PIREKO"
 $V=3000$ lit., PN 6
- 6- DOUBLE CIRCULATION PUMP "GRUNDFOS" TYPE TPD 125-130/4 A-F-A-GQQE
 $V=112$ m³/h
 $H=10,3$ mV.S.
 $Nel=2 \times 5,5$ kW
 400 V/3/150 Hz
- 7- DEVICE FOR PRESSURE MAINTAINING, EXPANSION, VENTING AND SUPPLEMENT OF THE SYSTEM "AIR-SEP" WITH MEDIA TANK
 7a - DEVICE FOR MAINTAINING PRESSURE AND REFILLING THE SYSTEM "AIR-SEP" TYPE AS E 100/4 M
 7b - PE MEDIA TANK (MIXTURE OF WATER AND ETHYLENE GLYCOL) WITH LIFT PUMP, V-2001
- 8- VERTICAL PLASTIC TANK
 $V=120$ l

Figure 1. Hydraulic scheme of the cooling system with the legend

4. DESCRIPTION OF PROPOSED AUTOMATIC CONTROL SYSTEM

The system is controlled by a programmable logic controller (PLC) via ethernet communication. The PLC collects all data from the entire system and, depending on it, controls the operation of the system and processes. A provided installation of eight temperature sensors and two pressure sensors in the system is ensured. Temperature sensors are placed in important places in the system, namely the inlet and outlet pipes of the chiller and at the inlet and outlet pipes of the dry coolers, for better information and system stability. The pressure sensors are placed on the cold-water return pipeline; one is placed in the primary circuit, and the other is in the secondary circuit of the cooling system. They are used to know the volume flow in the pipes, and if the pressure is within acceptable limits, then it can be concluded that the system works properly. There was no blockage in the pipes due to dirt or the influence of external stimuli that would jeopardize the correct operation of the system.

The control system is carried out in such a way that the system control mode can be selected on the control screen, either manually or automatically. The manually selected mode means that the desired air-cooled chiller is selected, through which the system's cooling is to be switched on. In this case, it is either the dry cooler or an

air-cooled chiller that is switched on by clicking the ON/OFF button on the screen. When the desired device is switched on, the cooling process begins. If everything goes well and without errors, the flow pump is also switched on, which starts automatically when one of the devices mentioned is in operation. The flow pump has a differential pressure sensor, which ensures the correct flow through the system. If automatic control mode is selected, the ambient temperature detected by the temperature sensor is considered. If the ambient temperature is higher than zero, the system operates in summer mode, and the air-cooled chiller is switched on. If the temperature is below zero or falls below zero while cooling and the air-cooled chiller is switched on, the chiller is switched off, and the dry cooler is switched on. During this period of switching the other cooling unit off and on, the supply pump is switched off to prevent excessive pressure and possible damage caused by this pressure. When the second cooling device starts cooling, and if everything is in order and there are no faults in the system, the flow pump resumes its work.

The given table 1 contains a list of PLC signals used in a specific cooling system. All signals, whether analog or digital, are fed to the PLC, which operates depending on these signals according to the written program and protocols that are programmed and specified in the form of a ladder diagram [15].

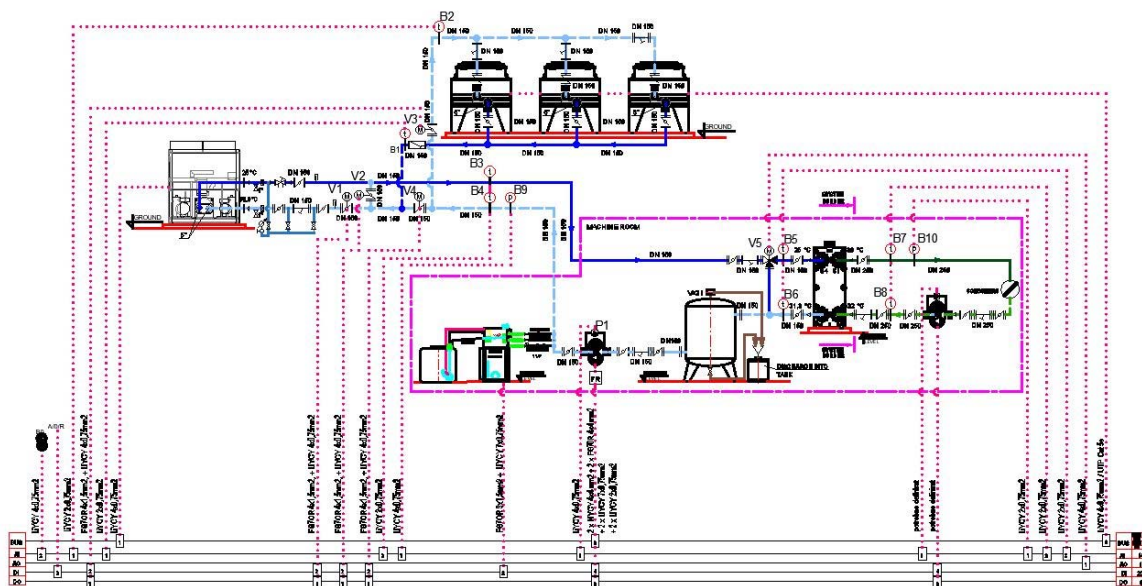

Figure 2. Scheme of cooling system with sensors and actuators in the field

An analog signal is a signal whose value constantly changes over time and is represented as a continuous signal, and is not a constant voltage signal. Depending on the conditions on site, the input and output signal can vary between 4-20 mA or 0-10 VDC. The digital inputs and outputs are binary inputs or outputs (values 0 or 1) that are fed to the PLC. The binary inputs are essentially voltages that vary between 5 V and 230 V, depending on the type of card used. They are used to check the status of any device, whether it is switched on or off. The digital outputs are used to switch field devices on and off.

Table 1. Number of analog and digital inputs and outputs in the control system

Analog inputs	Analog outputs	Digital inputs	Digital outputs
13	1	7	10

An actuator is a system component that is responsible for the movement and control of a mechanism or system. To do this requires a control signal and a power source. A sensor is a device that detects and responds to some type of input from the physical environment. Table 2 contains a list of the sensors and actuators used in this work. The left-hand column of the table contains a brief description of the element itself, while the right-hand column contains the name of the element manufacturer and its type.

Table 2. List of sensors and actuators in the control system

External temperature and relative sensor moisture	SIEMENS QFA3160
Immersion tube temperature sensor, NTC 10k, 100 mm	SIEMENS QAE2130.010
Pressure sensor for liquids, 0...10 bar	SIEMENS QBE2003-P10
Butterfly valve, PN 16, DN 150 + electro drive, 3-P AC 230 V	SIEMENS VKF46.150 + SQL36E65
Three-way valve, kvs = 315 m ³ /h + electro drive, AC 24 V, DC 0...10 V	SIEMENS VXF42.150-315 + SKC60
Differential pressure sensor, 0...5 bar	SIEMENS QBE61.3-DP5

5. DESCRIPTION OF DEVELOPED CONTROL ALGORITHM

The PLC product ©SIEMENS SIMATIC S7-1500 is programmed via a computer program ©SIEMENS TIA portal on a personal computer or programming device. The computer is connected to the PLC via Ethernet or RS communication. A computer programming program enables the input and editing of ladder logic [15]. Such logic in the form of a diagram represents the manner of electrical operation. In addition, they also represent the interconnection of external devices so that one device activates the function of another device according to a predetermined sequence of events.

The Profinet communication mode [16] was used in this work; a star-shaped network topology was used. For the Profinet network type, all IP addresses must be defined in order to be able to communicate.

The ©TIA Portal uses the IPv4 Internet protocol [17], where IP addresses and subnet masks are defined while the network card enables access to the ©TIA Portal. In addition, it is necessary to make all other settings in the ©TIA Portal, whereby the program can make most of these settings automatically.

The control algorithm contains an implemented PID algorithm [18] with the possibility of automatically adjusting its parameters. For this purpose, the ©TIA Portal computer program is used, which implements this with its subroutine. The adjustment is made when the system is first commissioned and after the overhaul or commissioning of the system, following a certain downtime. The values of the parameters are then set in the PID algorithm. The electric butterfly valves are opened and closed via their opening status (0 or 100 % open). It is also used when gradually opening and closing the electric three-way valve to maintain the temperature regime on the primary side of the plate heat exchanger.

Figure 3 shows the digital and analog modules defined at individual data storage addresses. It can be seen that the physical addresses of the digital inputs are from (0...1), i.e., two bytes are used, as the digital input is a 16-bit. The digital output is a 32-bit and uses 4 bytes from (0...3). As the analog signal is used as a 16-bit word, i.e., two bytes are used, addresses of (22...37) bytes are used for the analog input and (24...31) bytes for the analog output.

The list of selected DDC elements for cooling operation is shown in Table 3.

Table 3. List of selected DDC elements

DDC regulator (DI, DO, AI, AO)	TRANE UC600	1 piece
Additional modules (DI, DO, AI, AO)	TRANE XM70	2 pieces
Additional module (DI)	BTR BMT-DI10 BACnet MS/TP	1 piece
Additional module (DO)	BTR BMT-DO4 BACnet MS/TP	1 piece
iDisplay, Tablet computer	iDisplay Tablet 15.6"	1 piece

PM 190W 120/230VAC	0	0			PM 190W 120/230...
PLC_1	0	1			CPU 1516-3 PN/DP
plc_1.profinet interface_1	0	1 X1			PROFINET interface
PROFINET interface_2	0	1 X2			PROFINET interface
DP interface_1	0	1 X3			DP interface
DI 16x24VDC HF_1	0	2	0...1		DI 16x24VDC HF
DQ 32x24VDC/0.5A ST_1	0	3		0...3	DQ 32x24VDC/0.5...
AI 8x12/120/175 TC ST_1	0	4	22...37		AI 8x12/120/175 TC ST
AQ 4x12 ST_1	0	5		24...31	AQ 4x12 ST
	0	6			
	0	7			
	0	8			

Figure 3. List of analog and digital modules and their addresses

5.1 Main program

The main block contains all the function blocks that the PLC executes continuously, one after another, during system operation. The main block is a mandatory and integral part of every PLC program, i.e., if another block created for the system is not located within this main block, its commands are not executed. The specified blocks within the main program are processed one after another from top to bottom, as are the individual

command lines within these blocks. When all commands of the last block are executed, the program starts again by executing the first line in the specified block.

Figure 4 shows six function blocks that are created so that the standard system can perform its work correctly. They are designed based on the execution of individual work functions. There are also two automatically generated blocks (MC-Interpolator and MC-Servo) that originate from the functions for controlling the speed of the individual pumps in the system.

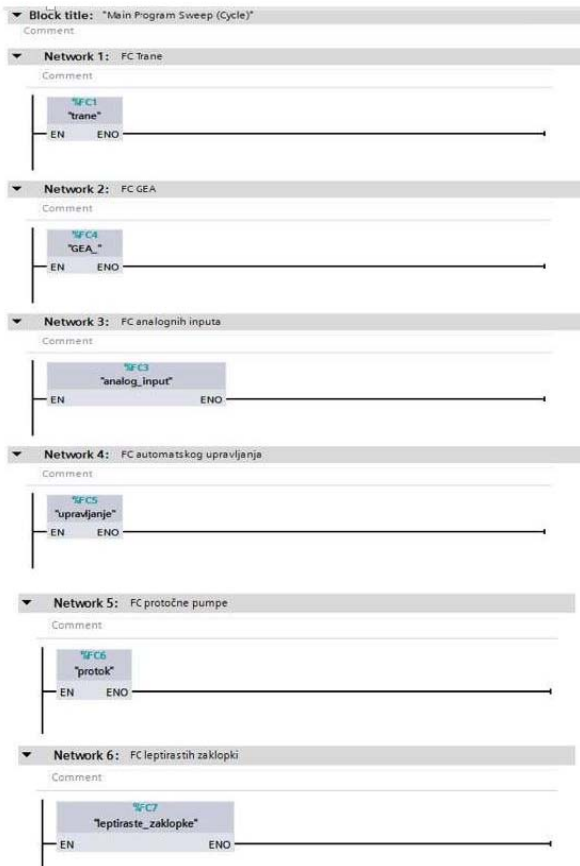

Figure 4. Main (OB1) block

5.2 Dry cooler program

The control program for the dry cooler is shown below (Figure 5). The program for the air-cooled chiller and the flow pump was based on the same principle, so this paper does not show these parts of the program in detail.

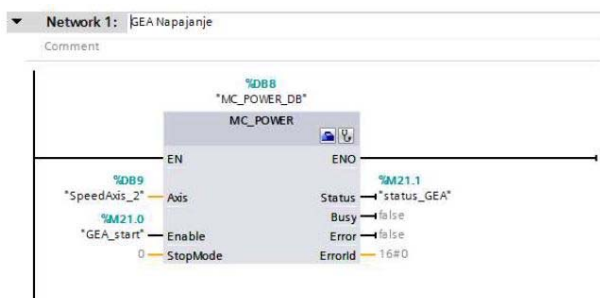

Figure 5. Main (OB1) block

The block in Figure 5 serves to turn on the power supply to the dry cooler. It contains the memory bit M21.0, which turns the power on and off depending on its logic state.

In addition, there is a MOVEJOG_DB data block (Figure 6), whose activation also uses the memory bit M21.1, which is a status bit from the MC_POWER data block and serves as a confirmation bit that the power is on and that the refrigerator compressor can start to work.

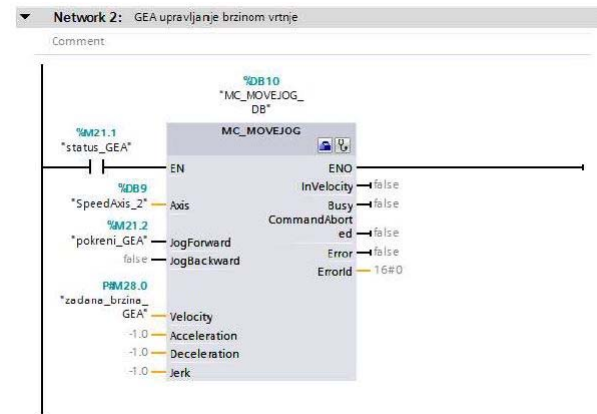

Figure 6. Block for controlling the rotation speed of the dry cooler fan

In addition, there is a block for defining all conditions (Figure 7) so that the dry cooler functions correctly and safely. The logical values of the memory bits of individual states of the system define the current phase in which the system is in but also define the condition under which the further process runs when a new change occurs.

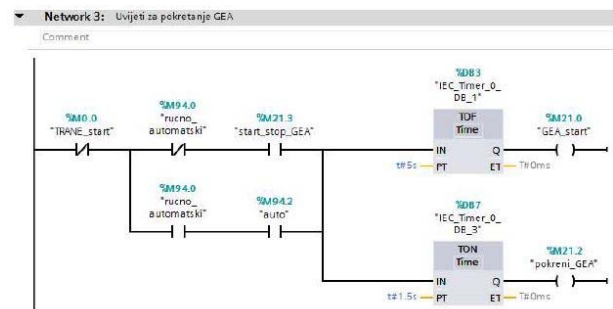

Figure 7. Block of conditions for starting dry cooler

5.3 Butterfly valve program

This program line (Figure 8) shows the conditions required for the throttle valves to function properly. The program prompts you to open and close these dampers. Care should be taken to ensure that the dampers establish the media flow to the chiller and for them to work alternately. You can choose between manual and automatic control modes in the control system.

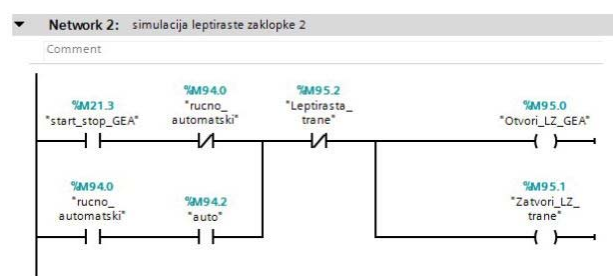

Figure 8. Block for butterfly valves

In addition, this part of the program ensures that the flaps are closed and opened in good time. Not all devices in the field can perform a certain function immediately after the command arrives. Therefore, each damper requires a certain amount of time to open and close, which is provided by the TON and TOF timers.

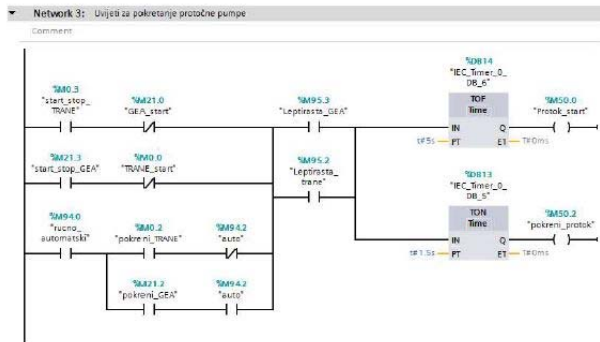

Figure 9. Block for flow pumps

5.4 Program of analog inputs

In these program lines (Figure 10), the analog input values read from the pressure and temperature sensors in the system are scaled. The input value of the analog signal is displayed as a 16-bit integer value. As this sixteen-bit value is reserved for a range of -10 V to +10 V, this is also the scaled maximum value of the pressure and temperature inputs. This is done for a specific reason, as these values cannot be less than zero in this system. The output values are displayed in real form so that they can be displayed on the screen of the SCADA monitoring system.

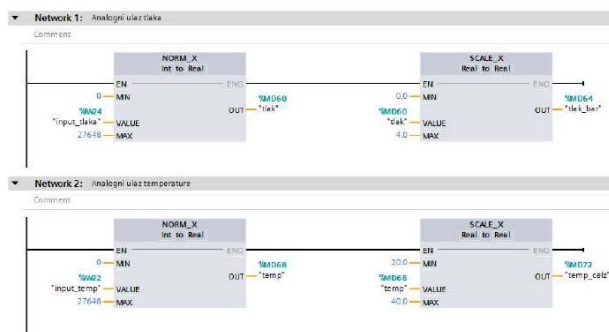

Figure 10. Block analog inputs

As the processes in the program do not take place in the real system, it is necessary to simulate external and internal processes, such as the external temperature, the temperature of cooling liquids, and the pressures in the pipes. The simulation was performed with an analog signal transmitter, and that signal represents the possible external temperature, which depends on how the system works.

5.5 Mode selection program

The program (Figure 11) is used to select the cooling mode when the automatic control mode is selected. It takes place and is determined according to the value of the outside temperature. If the outside temperature is below zero, dry cooling is switched on; if the temperature is above zero, water cooling is switched on.

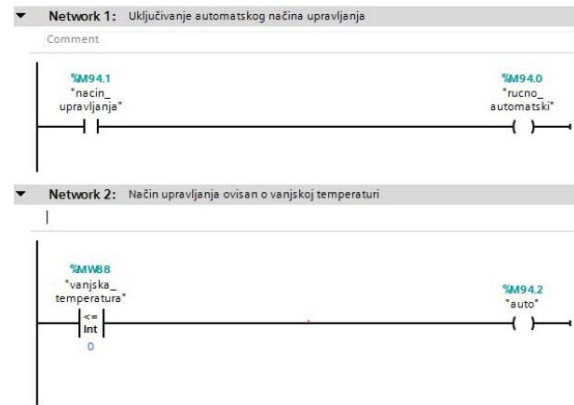

Figure 11. Block for selecting the regulation mode

6. DESCRIPTION OF DEVELOPED SCADA SYSTEM

In this work, a PC was chosen as the device through which the interaction between the device and humans is realized. It is also used for communication, i.e., for monitoring and managing the processes in the system. Screens are created in the ©WinCC interface, with which the operator can control and monitor the devices in the system. For this purpose, object templates that support process visualization, the creation of plant screens, and the definition of process values have already been created.

The screen contains static and dynamic elements. Static elements, such as text or graphic objects, do not change their status at runtime, while dynamic elements change their status depending on the process. The current values of the process are visualized as they follow the memory of the PLC and the memory of the HMI device in the form of alphanumeric displays, trends, and bars. In addition, it is necessary to define and organize the topology of the devices used in the system. The function keys of the HMI device can be assigned one or more functions in the ©WinCC program. They are started as soon as the operator presses the appropriate button on the HMI device. They can be assigned global or local functions. Global function keys always trigger the same action, regardless of the screen currently displayed. Local function keys trigger different actions depending on the screen currently displayed on the HMI device. The screen layout depends on the properties of the HMI device to be configured.

In the ©TIA portal, it is necessary to organize the topology of the devices used in the system. In Figure 12, it can be seen that it is also necessary to include the PC station on which the SCADA system is located as an additional device in the system and to define it correctly with an HMI connection with its IP address.

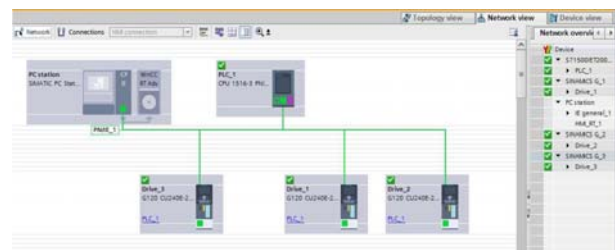

Figure 12. Device topology in ©TIA portal

Figure 13 shows the SCADA system screen for one of the system's operating modes during dry cooler operation.

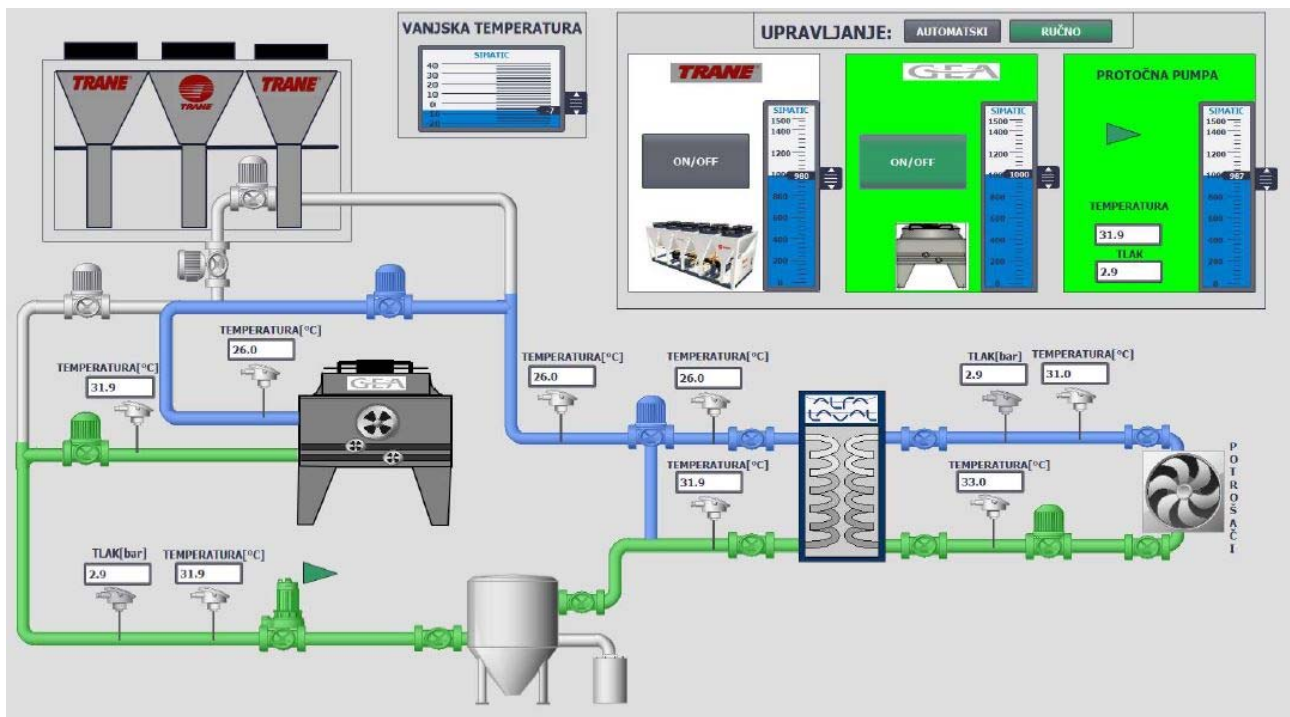

Figure 13. Screen display of SCADA system in the event of dry cooler operation

7. CONCLUSION

This work describes implementing a program for the automatic control of cooling systems, from conception to creation and operation display. It has been shown how an effective and automated system can be implemented using modern technology, which has been developed over several decades, and modern knowledge.

The implemented control system with SCADA has several advantages, such as:

- Practicality, as each process runs according to the desired and pre-planned conditions that meet the user requirements and are stored in the control program.
- The entire system and its processes are visible on the control and monitoring screen, through which the system communicates with the user. This makes it easier to detect errors and faults that occur within the system, as the control unit provides feedback if there is a fault in the system.

The most important contributions of this paper are as follows:

- The control system with a PLC controller and SCADA system has an implemented PID algorithm.
- The control system has the option of switching the operating modes from the standard cooling method to the dry cooling method and vice versa.
- The system can be controlled with a remote control and monitored via a computer or mobile device from another location.

One of the directions of future research would be to extend the above algorithm and interface to a more complex plant installation, such as a cooling station with water coolers and associated equipment installed in parallel. In addition, one could try to implement some of the adaptive control algorithms.

ACKNOWLEDGMENT

The research presented in this paper was conducted as part of the preparation of a Diploma thesis at the Graduate Study of Electrical Engineering at Zagreb University of Applied Sciences, Zagreb, Croatia, for student Andrija Topčić in 2021.

REFERENCES

- [1] Che, W.W., Tso, C.Y., Sun, L., Y.K. Ip, D., Lee, H., Y.H. Chao, C.Y. H. and Lau, A.K.H.: Energy consumption, indoor thermal comfort and air quality in a commercial office with retrofitted heat, ventilation and air conditioning (HVAC) system, *Energy & Buildings*, Vol. 201, pp. 202-215, 2019, doi: <https://doi.org/10.1016/j.enbuild.2019.06.029>
- [2] Strielkowski, W., Civín, L., Tarkhanova, E., Tvaronavičienė, E. and Petrenko, Y.: Renewable Energy in the Sustainable Development of Electrical Power Sector: A Review, *Energies*, Vol. 14, Paper 8240, 2021, doi: <https://doi.org/10.3390/en14248240>
- [3] Javaid, M., Haleem, A., Pratap Singh, R. and Suman, R.: Substantial capabilities of robotics in enhancing industry 4.0 implementation, *Cognitive Robotics*, Vol. 1, pp. 58-75, 2021, doi: <https://doi.org/10.1016/j.cogr.2021.06.001>
- [4] Kåberger, T.: Progress of renewable electricity replacing fossil fuels, *Global Energy Interconnection*, Vol. 1, No. 1, pp. 48-52, 2018, doi: <https://doi.org/10.14171/j.2096-5117.gei.2018.01.006>
- [5] Góra, P., Sroczan, E.M. and Urbaniak, A.: Programmable Logic Control (PLC) for Small Water Demineralization Plant, *IFAC Proceedings Volumes*, Vol. 25, Issue 25, pp. 251-256, 1992, doi: [https://doi.org/10.1016/S1474-6670\(17\)49613-3](https://doi.org/10.1016/S1474-6670(17)49613-3)

- [6] Bayindir, R. and Cetinceviz, Y.: A water pumping control system with a programmable logic controller (PLC) and industrial wireless modules for industrial plants - An experimental setup, *ISA Transactions*, Volume 50, Issue 2, pp 321-328., 2011, doi: <https://doi.org/10.1016/j.isatra.2010.10.006>
- [7] Morsi, I., El-Din, L.M.: SCADA system for oil refinery control, *Measurement*, Vol. 47, pp. 5–13, 2014, doi: <https://doi.org/10.1016/j.measurement.2013.08.032>
- [8] Faryal, A., Umer, F. Amjad, M., Rashid, Z.: Aoun Muhammad Modelling and Simulation of SCADA and PLC System for Power System Protection Laboratory, *Electrical, Control and Communication Engineering*, Vol. 17, No. 1, pp. 19–25, 2021, doi: <https://doi.org/10.2478/ecce-2021-0003>
- [9] Carvajal, C.P., Solís, L.A., Tapia, J.A., Andaluz, V.H.: SCADA/HMI Systems for Learning Processes of Advanced Control Algorithms. In: *IT Convergence and Security 2017, Lecture Notes in Electrical Engineering*, Vol. 450, 2017, Springer, Singapore, doi: https://doi.org/10.1007/978-981-10-6454-8_12
- [10] Rashad, O., Attallah, Morsi, I.: A smart PLC-SCADA framework for monitoring petroleum products terminals in industry 4.0 via machine learning, *Measurement and Control*, 2022, Vol. 55(7-8) 830–848, doi: <https://doi.org/10.1177/00202940221103305>
- [11] Məmmədli, M. and Kabaoglu, R.O.: Simultaneous Monitoring and Control of Automation Systems with SCADA Based PLC, *BSEU Journal of Science*, Vol. 8, No. 1, pp. 336-344, 2020, doi: <https://doi.org/10.35193/bseufbd.899424>
- [12] Shoga, T., Thelkar, A. R., Bharatiraja, C, Mitiku, S. and Adedayo, Y.: Self-tuning Regulator Based Cascade Control for Temperature of Exothermic Stirred Tank Reactor, *FME Transactions*, Vol. 47, Np. 1, pp. 202-211, 2019.
- [13] Osman, K., Alajbeg, T., Štefić, M., Perić, M.: Comparison of the theoretical mathematical model and the experimental approach in the development of an automatic control system in a smart family house, *Proceedings of SpliTech 2022 - 7th International Conference on Smart and Sustainable Technologies*, 2022, FESB, doi: <https://doi.org/10.23919/SpliTech55088.2022.9854273>
- [14] Osman, K., Štefić, M., Alajbeg, T., Perić, M.: Approach in development and implementation of automatic control system in a smart building, *Energy and Buildings*, Vol. 293, Paper 113200, 2023, doi: <https://doi.org/10.1016/j.enbuild.2023.113200>
- [15] Barker, M., Rawtani, J., Mackay, S.: 8 -Practical techniques in sequence control design, *Practical Batch Process Management*, pp. 70-85, 2005, doi: <https://doi.org/10.1016/B978-075066277-2/50008-6>
- [16] Neumann, P. and Pöschmann, A.: Ethernet-based real-time communications with PROFINET IO, in: *Proceedings of the 7th WSEAS international conference on Automatic control, modeling and simulation*, pp. 54–61, 2005, doi: <https://dl.acm.org/doi/10.5555/1983314.1983326>
- [17] Bakni, M., Hanboii, S.: A Survey on Internet Protocol version 4 (IPv4), *WikiJournal of Science*, Vol. 5, No. 1, 2022, doi: <http://dx.doi.org/10.15347/WJS/2022.002>
- [18] Borase, R.P., Maghade, D.K., Sondkar, S.Y. and Pawar, S.N.: A review of PID control, tuning methods and applications, *International Journal of Dynamics and Control*, Vol. 9, pp. 818–827, 2021, doi: <https://doi.org/10.1007/s40435-020-00665-4>

NOMENCLATURE

T_{amb}	ambient temperature
Q	output heat capacity
Q_{cool}	cooling capacity

Superscripts

amb	ambient
cool	cooling

Abbreviations

HMI	Human – Machine Interface
PC	personal computer
PLC	Programmable Logic Controller
SCADA	Supervisory control and data acquisition

ПРЕЗЕНТАЦИЈА АЛГОРИТМА УПРАВЉАЊА РАСХЛАДНИМ СИСТЕМОМ У ПОСЛОВНОЈ ЗГРАДИ

К. Осман, А. Топчић, М. Перић, Д. Стаменковић

Овај рад представља алгоритам за управљање и праћење расхладног система коришћењем интерфејса човек-машина (ХМИ) у пословној згради. Рачунарски програм за аутоматско управљање реализован је коришћењем рачунарског програма ©СИЕМЕНС ТИА портал. На основу претходно креиране хидрауличке шеме система креиран је лествичасти дијаграм који је ускладиштен у ПЛЦ-у са циљем даљег аутоматског управљања системом. Поред тога, имплементиран је СЦАДА систем за праћење свих процеса разматраног расхладног система. Систем управљања је пројектован као систем даљинског управљања са могућношћу подешавања и праћења система са удаљене локације преко рачунара или мобилног уређаја.