

Numerical and Multi-criteria Energy Flow Analysis in the Kragujevac Primary School

Aleksandar Nešović

Research Assistant
University of Kragujevac
Faculty of Engineering

Danijela Nikolić

Associate Professor
University of Kragujevac
Faculty of Engineering

Ana Radojević

University of Kragujevac
Faculty of Engineering

Abstract: In this investigation, a numerical and multi-criteria analysis of energy flow in the primary school in the city of Kragujevac is presented. A model of the existing school building with a district heating system was created. Alternative heating systems (the gas boiler, the pellet boiler, and the ground source heat pump) were analyzed to achieve energy savings. Different types of buildings are simulated with and without photovoltaic panels. Google SketchUp was used for building modeling, while EnergyPlus simulated buildings' energy behavior in real conditions. Results show that pellet boilers with photovoltaic panels can reduce primary energy by 89% and CO₂ emission by 87.55%. For the ground source heat pump with photovoltaic panels, the final energy saving is 77.83%, primary energy saving is 70.82%, and CO₂ reduction is 57.90%. Using numerical and multi-criteria analyses, the authors want to bring the existing public buildings closer to the zero-energy building concept and the city closer to the sustainable development concept.

Keywords: CO₂ emission, Energy consumption, EnergyPlus software, Heating systems, Multi-criteria analysis, Photovoltaic panels, Primary school.

1. INTRODUCTION

The energy crisis in Europe puts the focus on energy efficiency and the use of renewable energy sources (RES). Rational energy usage is extremely important, so it is necessary to implement projects aimed at carrying out activities for the implementation of various energy efficiency measures. At the same time, the use of RES technologies directly affects the reduction of greenhouse gas emissions, thus mitigating climate change and reducing the dependence on fossil fuels. In this manner, energy efficiency, climate change, and environmental protection are connected, as well as rational energy use and sustainable development.

In the EU, around 72% of the human population lives in urban areas. This share is assumed to reach around 80% [1] in 2050. Cities have a key role in implementing EU policy to improve energy efficiency, reduce energy consumption, and reduce CO₂ emissions. The building sector (BS) is responsible for 40% of global energy consumption and 30% of anthropogenic greenhouse gas emissions, while CO₂ emissions in the BS are at 38% [2]. Local authorities have a major role in the fight against climate change because a significant part of CO₂ emissions in cities comes from the BS.

Serbia has assumed obligations that are fully harmonized with the EU Directives regarding energy efficiency and climate change mitigation. Kragujevac, the fourth largest city in the Republic of Serbia, is a "green city" in which systems function by the principles

of rational energy use. The public building sector (PBS) represents a large potential for energy savings, with primary (PSs) and secondary (SSs) schools identified as the largest energy consumers. Therefore, improving their energy efficiency represents a major contribution to reducing energy consumption and CO₂ emissions.

There are 257 public buildings in Kragujevac, of which 90 are educational institutions (EIs). Regarding the total energy consumption, the facilities of EIs participate with 61%. The total annual electricity consumption in the PBS in Kragujevac is 10089.39 MWh. EIs have a total energy consumption of 3857.88 MWh (38.2%), while 1909.27 MWh is consumed in PSs (18.92% of the total energy consumption of PBS and 49.4% of EIs). All public buildings' total heating energy consumption is 26903.28 MWh, and 12510.67 MWh (46.5%) is consumed in PSs. Annual CO₂ emission for PBS in Kragujevac is 22246.17 t, of which 6406.22 t (28.9%) is related to the PSs [3]. With responsible energy and environmental policy, reducing consumption in this sector is possible, which in Serbia, even in Kragujevac, still needs more attention.

In modern scientific literature, many papers show that the right choice of heating system in public buildings is the first important step towards combining energy and environmental measures. The main goal of responsible energy and environmental management should be to minimize energy consumption in the building itself (while comfort conditions that must be met even in unforeseen circumstances [4, 5]), create a sustainable system, and ultimately preserve the environment. The concept of sustainable development is only possible with prior knowledge of all energy-ecological flows in the building.

Kazagic et al. [6] present the concept of a renewable district heating system (DHS), which was developed in

Received: September 2023, Accepted: February 2024

Correspondence to: Aleksandar Nešović
University of Kragujevac, Faculty of Engineering,
Sestre Janjić 6, 34000 Kragujevac, Serbia
E-mail: aca.nesovic@kg.ac.rs

doi: 10.5937/fme2402214N

© Faculty of Mechanical Engineering, Belgrade. All rights reserved

FME Transactions (2024) 52, 214-225 214

the municipality of Visoko, Bosnia and Herzegovina, which includes one high school (HS) and one PS. The result of the research is much better economic and environmental indicators of sustainability. A group of Italian scientists investigated the DHS used for heating the school complex in Podenzano (Emilia-Romagna region) [7]. The school complex consisted of a PS, HS, and a sports hall (SH). Two gas boilers (GBs) and one biomass boiler (BB) were used as heat sources. The obtained results emphasize the importance of boiler and circulation pump (CP) management strategy. De Lorenzi et al., in the research in [8], define a framework that includes all steps of controller development for small-scale DHS, from conceptualization to prototype testing. The new solution is economically more favorable by 6%, achieving energy savings of 34%. A centralized hybrid DHS from RES was analyzed using the TRNSYS package in [9]. The model was based on the exploitation of solar energy integrated with seasonal borehole thermal energy storage for the needs of 6 residential buildings (RBs) and 3 schools.

Stocker et al. analyzed cost-optimal arrangements of heating energy characteristics for 8 different PSs in the Alps region [10]. Heating energy systems and their energy efficiency were considered in the study, and the change to a more efficient system is proposed in every case. In [11], Morshed used a numerical simulation approach to analyze the effects of natural ventilation on air quality and thermal comfort in the example of classrooms in SS.

The study was carried out in [12] with the goal of examining the possibility of installing a pellet boiler (PB) in PS Lukavica, Bosnia and Herzegovina, as a replacement for the existing GB.

Italian scientists presented an analysis of the operation of the HVAC installation for 12 months in a new school in the territory of northern Italy [13]. This system is composed of a ground source heat pump (GSHP), a solar system, and a heat recovery system (HRS). The results indicated that integrating different heat sources improves the thermal performance of the entire heating installation, which results in significant energy savings. At the same school, a dynamic simulation was carried out for GSHP and photovoltaic thermal collectors (PVT) [14], and the monitoring of the operation of the thermo-technical systems in real-time (during the period of two heating seasons) [15].

Final energy consumption in a school building (SB) in the south of Germany (Bavaria), which uses a GSHP in combination with a classroom ventilation system, was analyzed in [16]. A feasibility study for combining the hybrid fuel cells and GSHP in air conditioning systems in schools in the territory of northwestern Algeria was carried out [17].

A simulation (in the TRNYS software package) of the thermal performance of hybrid GSHP in the SB located in southern Europe (Greece) was performed by Androulakis et al. [18]. Programs for determining the energy performance of GSHP and minimizing energy consumption in three different public buildings in the USA have been given by Martin et al. in [19]. Allaerts et al. analyzed improving the energy efficiency of GSHP in heating systems in SBs in Belgium [20].

The study carried out in [21] dealt with installing photovoltaic (PV) systems in school units in the territory of Greece within the framework of existing national legislation and EU directives. Shaari and Bowman simulated the operation of building-integrated PV applications (BIPV) on a standard SB in Malaysia, showing that the potential of using PV technologies is significantly higher than expected, and energy saving is significant [22]. A study conducted on the SB in Turkey by Yilmaz et al. [23] showed that the use of PVs can cover 28-80% of electricity needs, depending on the month of the year. Bilir and Yildirim, in their paper [24], analyzed 265 PVs that were used on the school roof in Izmir. Obtained results showed that they can meet 65% of school electricity needs. Cholakkal gave a case study of the SB in Blacksburg (Virginia), where he applied multiple linear regression to develop a model that would be used to evaluate the economics of the BIPV roof system connected to the utility network [25].

The concept of Zero Energy buildings (ZEBs) [26] can be applied to all sectors. Lou et al. analyzed the ZEBs concept in school designs [27]. They used the eQUEST software package to investigate electricity production from the PVs in the SB located in Hong Kong. The results show that achieving ZEB in the analyzed school is possible. Attia et al. carried out numerical investigations in EnergyPlus software [28] for two models of nearly Zero energy buildings (NZEBs) in Belgium (PS and SS). Both schools have gas heating systems and passive designs. The obtained results on energy needs (for electricity and gas) and energy use intensity are useful in similar continental climate conditions. Moazzen et al., in their investigation [29], gave the multi-criteria approach for energy efficient measures with cost analysis, payback period, and CO₂ emission for PSs retrofit. The results show that the potential of primary energy savings and CO₂ emission reductions is about 60%, and payback periods are less than seven years.

Increasing energy efficiency in the SBs can only be imagined by using RES (mainly solar [30, 31] and geothermal [32], sometimes wind energy [33]). The same applies to the NZEB and ZEB concepts.

The literature review of previous papers is based on case study analyses in which the existing heating system was replaced with another alternative type of heating system.

However, the instability of the global energy sector and the variation in the market prices of available fuels have shown that such analyses should not be limited to individual alternative solutions. The problem must be looked at in a much broader way because the alternative heating system should contribute to energy saving, greater energy independence of the building, as well as environmental protection to help the city move in the direction of sustainable environments.

Multi-criteria analysis is of high importance in these cases because it is a method that can be used to analyze multiple options to determine the best choice, especially in a situation where more different but significant criteria have to be included in the decision-making process.

Considering all of the above, this paper presents a comprehensive study of energy flows in the PS (case study), applying multi-criteria analysis to determine the

best solution for the school heating system. A model of the existing PS with a DHS was created using EnergyPlus software and validated by comparing the predicted (simulated) and real (five-year sample) heating energy consumption data.

The alternative heating systems considered are the GB, the PB, and the GSHP. Unlike previous research, the authors of this paper, using the example of the PS, took into account 3 energy-environmental indicators (final energy consumption, primary energy consumption, and CO₂ emission) to make the existing DHS with another (alternative) heating system.

The paper also considered the integration of the PV system (on the roof of the analyzed SB) with the mentioned heating systems to improve the energy-ecological parameters even more. The methodology presented in this paper (based on the numerical and multi-criteria analysis) can be applied to other regions (with the same or similar climate and topography) on the other BS.

2. RESEARCH SUBJECT

2.1 Model of analyzed primary school building

A multi-criteria energy flow analysis was performed for PS located in the city of Kragujevac in this investigation (Figure 1). The current SB was built in 1978, and it consists of 26 classrooms, a teacher's office, hallways, a SH (398 m²), and utility rooms. PS is modeled in Google SketchUp software.

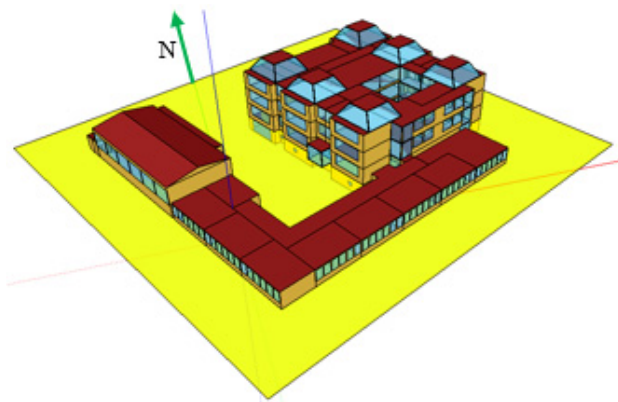

Figure 1. Isometric view of the modeled PS

The PS has a total floor area of 4424.74 m² and four floors: the basement with an area of 683.3 m², the ground floor with an area of 1986.94 m², the first floor with an area of 823.55 m², and the second floor with an area of 930.95 m². The total area of the PS thermal envelope is 8148.03 m². The main entrance is oriented to the southwest.

The PVC windows are double-glazed with a U value of 1.46 W/m²K. In 2017, a complete replacement of the previous wooden carpentry in the PS and thermal envelope insulation was carried out. The brick building envelope and the floor are thermally insulated by polystyrene. Thermal insulation thickness is 5 cm with a U value of 1.48 W/m²K (for exterior walls) and 0.97 W/m²K (for ground floor). The roof is insulated by mineral wool. Insulation thickness is 5 cm, with a U value of 1.04 W/m²K. These building materials and

constructions are usual in Serbian buildings and correspond to typical Serbian construction materials from the 1970s.

Simulations were carried out for the heating season, i.e., for the period from October 15 to April 15, and the simulation time step was 15 min.

2.2 District heating system

The DHS is the most common type of heating in urban areas. This system represents a unique system of interconnected energy facilities that serve to produce, transmit, and distribute thermal energy. The analyzed PS was connected to the DHS of the city of Kragujevac (Figure 2). The basic parts of this system are the city energy plant (CEP), the plate heat exchanger (PHE) inside the PS, radiator heaters (RAD) inside the thermal zones of the PS, and two CPs.

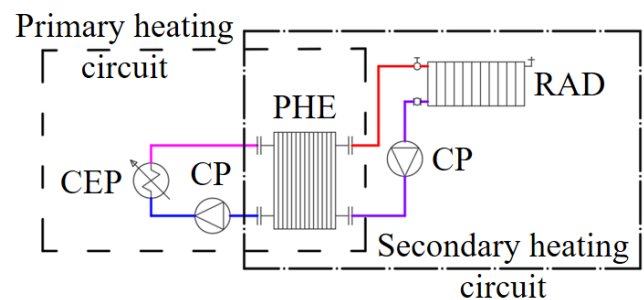

Figure 2. Scheme of DHS in the PS

The EnergyPlus program simulates the use of DHS in buildings by enabling the user to simulate the energy behavior of the building without specifying the operating parameters of the boiler. This model requires the connection to the radiator system of the simulated RB in a closed loop and to know the plant's nominal capacity. The DHS operates from October 15 to April 15 (next year). Air temperatures in the PS thermal zones are set to 20°C (from 07:00 h to 21:00 h) and to 15°C (from 21:00 h to 07:00 h the next day).

2.3 Electricity and heating energy consumption

The real electricity ($E_{FIN-EL-r}$ [MWh]) and heating ($E_{FIN-H-r}$ [MWh]) energy consumption in the PS in the territory of Kragujevac (2015-2019, before the COVID-19 pandemic) is shown in Figure 3.

The real $E_{FIN-EL-r}$ is uneven during the analyzed period. Value $E_{FIN-EL-r}$ depends on a variety of other factors: meteorological conditions, the structure of classes, vacations, the schedule of use of electrical devices, etc.

Taking all of the above into account, by the data from [3], the real $E_{FIN-EL-r}$ during this period was (Figure 3): 81.73 MWh (2015), 87.71 MWh (2016), 91.29 MWh (2017), 86.71 MWh (2018), and 90.22 MWh (2019).

The highest consumption of $E_{FIN-H-r}$ in the PS was recorded in 2016, when it amounted to 713.09 MWh, then followed in 2015 (704.54 MWh). Replacement of the carpentry and insulation of the thermal envelope of the PS in the summer of 2017, resulted in a reduction of the real $E_{FIN-H-r}$ by 40.9% compared to 2016 (421.46 MWh, Figure 3). In 2018 and 2019, the real $E_{FIN-H-r}$ in the

PS was 428.56 MWh and 380.71 MWh, respectively. The reduction of the $E_{FIN-H-r}$ was 39.9% in 2018 and 46.6% in 2019. From the analyzed data, it can be concluded how much the basic measures of improving energy efficiency affect the reduction of $E_{FIN-H-r}$ in the PS.

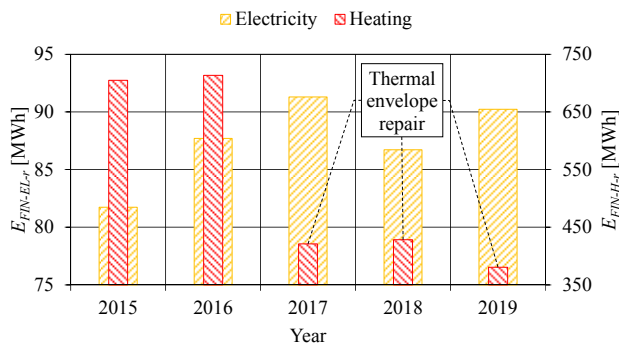

Figure 3. Real electricity and heating consumption in the PS

Real specific heating energy consumption ($E_{FIN-H-r(spec)}$ [kWh/m^2]) and energy class of the investigated PS (by the Rulebook on energy efficiency of buildings in the Republic of Serbia, [34]) are given in Table 1.

Table 1. Real-specific heating energy consumption and energy class of the PS

Year	$E_{FIN-H-r(spec)}$ [kWh/m^2]	PS energy class
2015	161.05	E
2016	159.22	E
2017	95.25	C
2018	96.36	C
2019	86.04	C

Before the renovation and improvement of the thermal envelope, PS was an “E” energy class with a very high real $E_{FIN-H-r(spec)}$ (about 160 kWh/m^2). After building insulation and carpentry replacement, the building energy class was improved to the “C” energy class, with real $E_{FIN-H-r(spec)}$ values in the range of 86.04 to 96.36 kWh/m^2 .

Improving the energy efficiency of the PS gave significant energy savings, but the SB is still energy inefficient, so it is necessary to take additional measures for energy efficiency improvement.

3. ALTERNATIVE THERMO-TECHNICAL SYSTEMS

Public buildings generally have energy efficiency issues as they have old and inefficient heating systems. There are different problems encountered in public buildings: too hot or too cold in the occupied zones, high energy consumption without internal comfort, bad management and control of the system, etc.

Minimizing energy loss is possible with regular maintenance. An effective heating system in all public buildings, especially at PSs, is very important. Too hot or too cold a school classroom can hurt pupils' concentration and learning ability. Classrooms have to be kept at certain temperatures so that people using them feel comfortable, healthy, and safe. This can be achieved by using various well-designed heating systems.

3.1 Gas heating system

Boiler heating systems are a safe, low-cost method for heating schools. GBs are environmentally preferable to coal or oil because their emissions are less harmful, and they can achieve significant primary energy savings. A gas heating system consists of a CP, a GB, a bypass line, a splitter, a collector-distributor, and RADs distributed in the thermal zones of the PS.

With these heating systems, thermal energy is generated in the GB and transmitted to the RADs by the working fluid. The elements of the heating system are the same as those of the DHS, with the addition of a GB. The sensor at the exit of the heat exchanger is used to achieve the desired temperature. The efficiency of the GB used in the simulations was 98%, and the output temperature of the water from the GB was 60°C .

3.2 Pellet heating system

Heating with wood pellets is becoming a common heating system in PBSs, EIs, etc. Wood pellets are compressed by-products from the forest products industry (woodchips and sawdust). The components of this heating system are a PB, a storage silo, a fuel conveyor system, electronic controls, a chimney, plumbing connections, and an ash removal system.

Wood PBs are relatively simple systems that are easily installed and operated. The wood pellets are stored in an outdoor silo and automatically fed to the PB. The combustion fan supplies air to the combustion chamber. Ash must periodically be removed.

3.3 Ground source heat pump

The GSHP (Figure 4) is connected externally to vertical geothermal boreholes (VGB). The VGBs are connected to the GSHP evaporation section during the heating season.

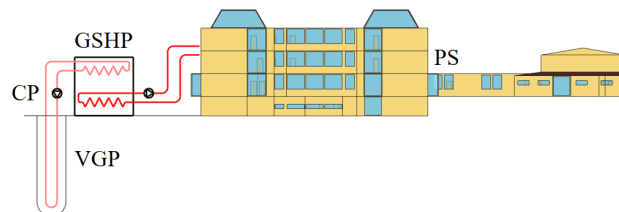

Figure 4. Scheme of GSHP in the PS

The GSHP and VGB (primary piping, CPs, valves, etc.) form the primary heating circuit.

The GSHP condenser section forms the secondary heating circuit (Figure 4), heating elements that play the role of end users (for example, floor heating, fan coil units, etc.), and the secondary pipe network with accompanying equipment.

3.4 Photovoltaic system

To further improve the energy efficiency of the considered PS, in addition to replacing carpentry and installing thermal insulation, it was established that the school has great potential for installing PV panels due to the large free area of the roof.

Installation of PV panels allows for a significant reduction in electricity consumption of the PS. In this study, the PV system is modeled in EnergyPlus software, and operations of the PV and heating systems are simulated simultaneously. The PV system consists of PV panels and an inverter, and it runs during the entire year. The Simple model of PV panels with a cellular efficiency of 12% was used. A modeled PV system is an on-grid system (it entirely or partially covers electricity consumption in the PS).

Having in mind the building orientation, specific factors of the building shape, the influence of the shadow due to the orientation of the building and its design, as well optimal angle of inclination (for the city of Kragujevac $\beta=37.5^\circ$ [35]), it is possible to place a total of 160 monocrystalline PV panels on the PS roof. The dimension of the one PV panel is $1940 \times 990 \times 40$ mm, and the total output (maximum) power is 54.4 kW [36]. An isometric view of the conceptual design of PV panels on the roof of the PS is shown in Figure 5.

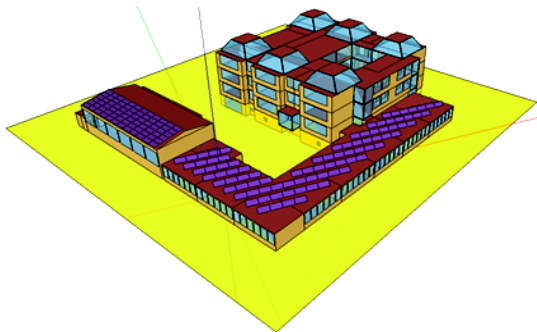

Figure 5. PV system on the PS roof

4. MATERIALS AND METHODS

4.1 EnergyPlus software

This software models heating, cooling, lighting, ventilation, and other energy flows, as well as the water network in the building. It includes many innovative simulation capabilities, such as time intervals of less than one hour, automatic systems, thermally balanced simulation zones, airflow through all thermal zones, thermal comfort, water usage, and natural ventilation.

EnergyPlus has its roots in the BLAST and DOE-2 software packages. Like its predecessors, EnergyPlus is a program for energy and thermal analysis and simulation. Based on the user's definition of a building, in terms of physical limitations and dependent mechanical parameters, EnergyPlus software calculates the heating and cooling parameters that are necessary to maintain thermal comfort inside the building [37].

4.2 Location parameters

Kragujevac (with time zone GTM+1 h) is a city in the Sumadija region (the central part of Serbia, located 100 km south of Belgrade, the capital of Serbia). The city covers an area of 835 km^2 , and it is located at an altitude of 173-220 m above sea level.

Kragujevac has a moderately continental climate with distinct seasons. Summers are hot and humid (temperature reaches 37°C), while winters are cold

(temperatures drop to -12°C) and with snow. The city's geographical position is $44^\circ22' \text{ N}$ and $20^\circ56' \text{ E}$.

The real and simulated values of the average monthly air temperature for the city of Kragujevac are shown in Figure 6 [3, 37].

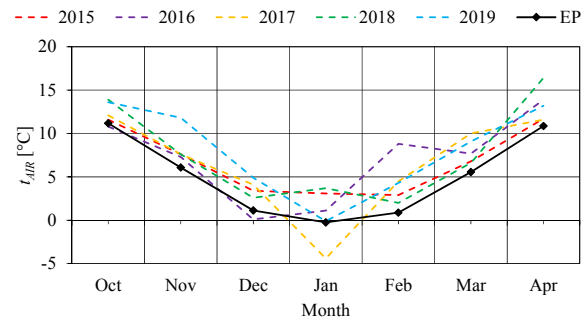

Figure 6. Average monthly air temperature for the heating season in the city of Kragujevac

From Figure 6 it can be noticed that the average monthly air temperature values are almost always above the data from EnergyPlus software.

A larger discontinuity was recorded only during January 2017 (-0.2°C – EnergyPlus value, -4.4°C – real value). The reason for this difference is that EnergyPlus software uses weather data from its weather files. These data are collected over several years and averaged to obtain data for a typical meteorological year used in the simulations.

4.3 Teaching process structure

School classes function in two shifts. The first shift (Figure 7) lasts from 07:30-12:40 h, and the second shift (Figure 8) lasts from 14:00-19:10 h. The total number of users of the SB is 879 (students, teachers, and technical staff).

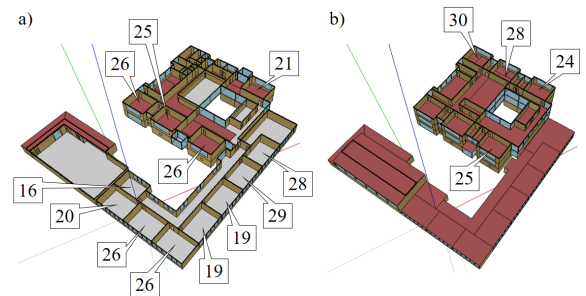

Figure 7. Schedule of classrooms used in the first shift: (a) Ground floor, (b) First floor

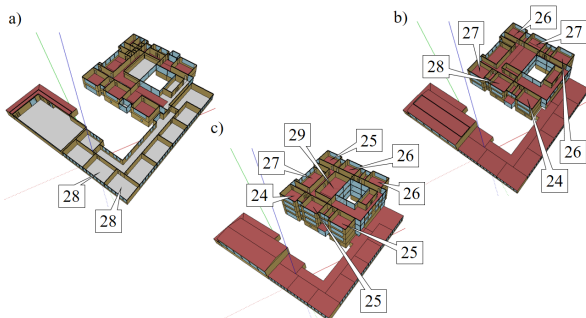

Figure 8. Schedule of classrooms used in the second shift: (a) Ground floor, (b) First floor, (c) Second floor

There are different schedules for attending classrooms in the first and second shifts. Figure 7 presents

classroom schedules for the first shifts and lower grades, with pupil numbers. Figure 8 presents classroom schedules for the second shift, higher grades, and pupil numbers. In both shifts, there are 16 occupied zones. The difference is only in the position of the classrooms (different floors).

5. SIMULATED SCENARIOS AND MCA ANALYSIS

In this paper, the PS with an existing DHS is simulated in EnergyPlus software. Also, the use of the following alternative heating systems was considered: the GB, the PB, and the GSHP. To reduce the consumption of electricity, scenarios were developed in which the mentioned heating systems are combined with a PV system.

Improvement of energy and environmental efficiency of the PS is carried out through the multi-criteria analysis algorithm, shown in Figure 9.

Two groups of influencing factors form the initial basis of the algorithm: the type of heating and the characteristics of the thermal envelope of the building (with and without thermal insulation and new efficient PVC windows).

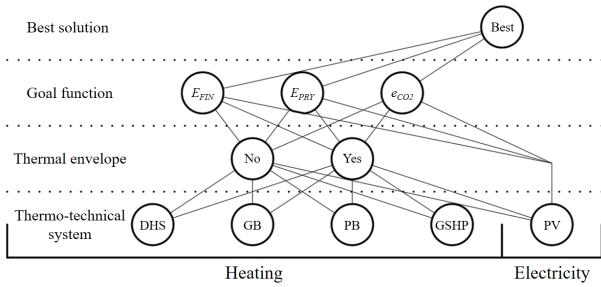

Figure 9. Multi-criteria analysis and defined simulation scenarios

The goal function (best solution) should arrive at the best measure taking into account two energy indicators (final energy consumption E_{FIN} and primary energy consumption E_{PRY}) and one environmental indicator (total CO₂ emission e_{CO_2}).

The ISO 50002 standard specifies requirements for conducting energy audits related to energy performance. It applies to all types and forms of energy use. This paper proposes a multi-criteria decision-making method (MCDM) that uses the Weighted Sum Model (WSM).

This model considers decision-maker preferences in determining the weights of the criteria [38]. It is a relatively simple model, and it provides relevant and reliable results. For each proposed energy conservation measure (ECM), a WSM score S_i is calculated Eq. (1):

$$S_i = \sum_{j=1}^n w_j x_{ij}, \text{ for } i=1, 2, \dots, NOP. \quad (1)$$

This analysis used three criteria: final energy saving, primary energy saving, and annual CO₂ emission reduction. The values of weight factors w_j are determined by their importance (their sum should be 100%).

6. ENERGY FLOWS

6.1 Final energy consumption

The simulated final energy consumption E_{FIN-s} [MWh] in the PS during the heating season is equal to the sum of electricity $E_{FIN-EL-s}$ [MWh] and heating $E_{FIN-H-s}$ [MWh] energy consumption Eq. (2):

$$E_{FIN-s} = E_{FIN-EL-s} + E_{FIN-H-s}. \quad (2)$$

Electric equipment E_{EE} [MWh], electric lighting E_L [MWh], and compressors E_{GSHP} [MWh] (in the case of using GSHP) contribute to the consumption of the simulated electric energy $E_{FIN-EL-s}$.

On the other hand, final energy consumption can be reduced by using PV panels, which generate electrical energy. The electrical energy generated by PV panels is E_{PV} [MWh].

Taking into account all the mentioned influential parameters, simulated final energy consumption $E_{FIN-EL-s}$ in the PS can be mathematically written as Eq. (3):

$$E_{FIN-EL-s} = E_{F,EE} + E_{F,L} + E_{F,GSHP} - E_{F,PV}. \quad (3)$$

The values $E_{F,EE}$ Eq. (4), $E_{F,L}$ Eq. (5), $E_{F,GSHP}$ Eq. (6), and $E_{F,PV}$ Eq. (7) [37], are:

$$E_{F,EE} = f_{EE} \cdot P_{EE} \cdot \tau_{EE}. \quad (4)$$

$$E_{F,L} = f_L \cdot P_L \cdot \tau_L. \quad (5)$$

$$E_{F,GSHP} = \frac{E_{PS-H-s}}{\eta_{PN} \cdot \eta_{CV} \cdot COP}. \quad (6)$$

$$E_{F,PV} = A_{PV} \cdot f_{PV} \cdot I_{PV} \cdot \eta_{PV} \cdot \eta_{INV}. \quad (7)$$

The simulated heating energy consumption is determined by Eq. (8) for the DHS $E_{F,DHS}$ [MWh], Eq. (9) for the GB $E_{F,GB}$ [MWh], and Eq. (10) for the PB $E_{F,PB}$ [MWh]:

$$E_{F,DHS} = \frac{E_{PS-H-s}}{\eta_{PN} \cdot \eta_{CV} \cdot \eta_{PHE}}. \quad (8)$$

$$E_{F,GB} = \frac{E_{PS-H-s}}{\eta_{PN} \cdot \eta_{CV} \cdot \eta_{GB}}. \quad (9)$$

$$E_{F,PB} = \frac{E_{PS-H-s}}{\eta_{PN} \cdot \eta_{CV} \cdot \eta_{PB}}. \quad (10)$$

According to the recommendations from the Rulebook on energy efficiency of buildings in the Republic of Serbia [34], the following coefficients are adopted: $COP=4.6$, $\eta_{PN}=0.95$, $\eta_{CV}=1$, $\eta_{PHE}=0.93$ (for the DHS), $\eta_{GB}=0.94$ (for the GB), and $\eta_{PB}=0.9$ (for the PB).

6.2 Primary energy consumption

The simulated primary energy consumption E_{PRY-s} [MWh] in the PS during the heating season consists of two terms: primary electricity consumption $E_{PRY-EL-s}$ [MWh] and primary heating energy consumption $E_{PRY-H-s}$ [MWh]. It can be determined using Eq. (11):

$$E_{PRY-s} = E_{PRY-EL-s} + E_{PRY-H-s}. \quad (11)$$

The value $E_{PRY-EL-s}$ is in the function of the primary energy conversion multiplayer K_{PRY-EL} ($K_{PRY-EL}=2.5$ for electricity [34]) Eq. (12):

$$E_{PRY-EL-s} = K_{P,EL} \cdot E_{FIN-EL-s} \quad (12)$$

The value $E_{PRY-H-s}$ is in the function of the coefficient K_{PRY-H} Eq. (13):

$$E_{PRY-H-s} = K_{P,H} \cdot E_{FIN-H-s} \quad (13)$$

The $E_{PRY-H-s}$ can be transformed to Eq. (14) for the DHS $E_{P,DHS}$ [MWh], Eq. (15) for the GB $E_{P,GB}$ [MWh], and Eq. (16) for the PB $E_{P,PB}$ [MWh]:

$$E_{P,DHS} = K_{P,DHS} \cdot E_{F,DHS} \quad (14)$$

$$E_{P,GB} = K_{P,GB} \cdot E_{F,GB} \quad (15)$$

$$E_{P,PB} = K_{P,PB} \cdot E_{F,PB} \quad (16)$$

Primary energy conversion multiplies for different heating systems are [34]: $K_{P,DHS}=1.8$ (for the DHS), $K_{P,GB}=1.1$ (for the GB), $K_{P,PB}=0.1$ (for the PB).

6.3 Gas emissions

CO_2 emission e_{CO_2-s} [kg] is equal to the sum of the emission that comes from the use of electricity, e_{CO_2-EL-s} [kg], and emission that comes from the heating system, e_{CO_2-H-s} [kg]. This value can be determined by Eq. (17):

$$e_{CO_2-s} = e_{CO_2-EL-s} + e_{CO_2-H-s} \quad (17)$$

Keeping this in mind, emission e_{CO_2-EL-s} Eq. (18), and e_{CO_2-H-s} Eq. (19), are:

$$e_{CO_2-EL-s} = m_{CO_2,EL} \cdot E_{PRY-EL-s} \quad (18)$$

$$e_{CO_2-H-s} = m_{CO_2,H} \cdot E_{PRY-H-s} \quad (19)$$

The emissions for the DHS $e_{CO_2,DHS}$ [kg] Eq. (20), for the GB $e_{CO_2,GB}$ [kg] Eq. (21), and the PB $e_{CO_2,PB}$ [kg] Eq. (22), are:

$$e_{CO_2,DHS} = m_{CO_2,DHS} \cdot E_{P,DHS} \quad (20)$$

$$e_{CO_2,GB} = m_{CO_2,GB} \cdot E_{P,GB} \quad (21)$$

$$e_{CO_2,PB} = m_{CO_2,PB} \cdot E_{P,PB} \quad (22)$$

Values $m_{CO_2,EL}$, $m_{CO_2,DHS}$, $m_{CO_2,GB}$, and $m_{CO_2,PB}$, are [34]: 0.53 kg/kWh, 0.33 kg/kWh, 0.2 kg/kWh, and 0.26 kg/kWh, respectively.

7. RESULTS AND DISCUSSION

7.1 Heating energy consumption

Figure 10 shows the simulation results (in EnergyPlus software) for heating energy consumption (final energy) $E_{FIN-H-s}$ in the PS, for two cases: before sanitation (without thermal insulation, with wooden windows $U=2.3$ W/m²K) and after sanitation (improving building envelope with polystyrene thermal insulation $\delta=5$ cm, and PVC windows $U=1.46$ W/m²K).

For the PS before sanitation, $E_{FIN-H-s}$ was 857.8 MWh. For the PS after renovation and sanitation, $E_{FIN-H-s}$ was 530.4 MWh. This means that changes in the thermal envelope lead to savings of 38.17%. Before the thermal envelope improved (2016, Figure 3), $E_{FIN-H-r}$ was 713.09 MWh (obtained simulated consumption is

16.87% higher than the real). After improving the thermal envelope, $E_{FIN-H-r}$ was 421.46 MWh (obtained simulated consumption is 20.54% higher than the real consumption in 2017).

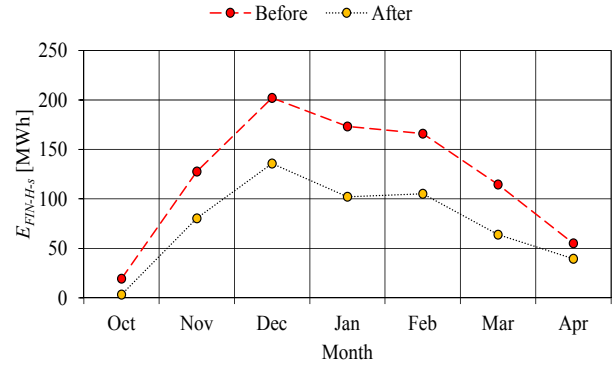

Figure 10. Simulated monthly heating energy consumption before and after thermal envelope sanitation in the PS

The differences between real and simulated consumption can mostly be explained by anomalies in (real and simulated) meteorological data (Figure 6) for the city of Kragujevac. For this reason, validating the results for heating energy consumption obtained by simulation was necessary.

7.2 Validation of the simulated results

The functional dependency between $E_{FIN-H-r}$ and $E_{FIN-H-s}$ for the period 2015-2019 is shown in Figure 11.

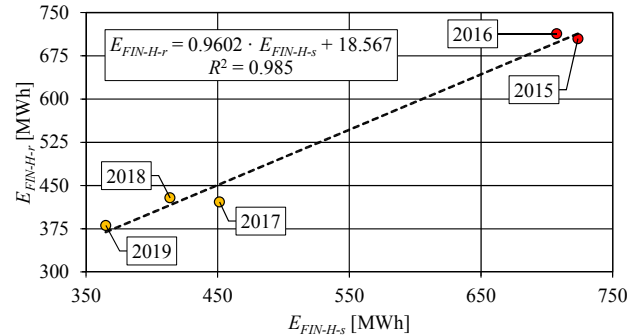

Figure 11. Functional dependency between real and simulated heating energy consumption in the PS

Data for $E_{FIN-H-r}$ was determined based on the payment invoice for heating in the PS (according to Figure 3). Data for $E_{FIN-H-s}$ is based on the use of a meteorological weather file for the city of Kragujevac (EnergyPlus software).

Validation of simulated results was done to reduce and eliminate the difference in these data. In other words, $E_{FIN-H-s}$ was validated with the coefficient of determination $R^2=0.985$ for the data of the PS before thermal envelope restoration (2015 and 2016) and for the data of the PS after thermal envelope restoration (2017, 2018, and 2019).

7.3 Final energy consumption in PS with alternative heating systems

Results for E_{FIN-s} in the PS with different heating systems, by month, during the heating season, are shown in Table 2.

Table 2. Simulated monthly final heating energy consumption with different heating systems in the PB

Month	Final energy consumption [MWh]				
	E_{PS-H-s}	$E_{F,DHS}$	$E_{F,GB}$	$E_{F,PB}$	$E_{F,GSHP}$
Oct	3	3.4	3.37	3.51	0.69
Nov	71.06	80.43	79.58	83.11	16.26
Dec	119.89	135.7	134.26	140.22	27.44
Jan	90.22	102.11	101.03	105.52	20.64
Feb	92.98	105.24	104.12	108.75	21.28
Mar	56.47	63.92	63.24	66.05	12.92
Apr	34.99	39.61	39.17	40.93	8.01
Tot	468.62	530.41	524.77	548.09	107.24

During the heating season, E_{PS-H-s} in the PS (Figure 1, Table 2) is 468.62 MWh. Calculated values for different E_{FIN-s} are: $E_{F,DHS}=530.41$ MWh, $E_{F,GB}=524.77$ MWh, $E_{F,PB}=548.09$ MWh, and $E_{F,GSHP}=107.24$ MWh.

Compared to the applied DHS in the PS, the GB is better at 1.06%. On the other side, the PB is a worse choice (for 3.33%). The GSHP is better than DHS, even by 79.78%. This fact shows that the GSHP may be a good choice for an alternative heating system in the PS, but further investigation is necessary because of the other energy-ecology parameters of the GSHP.

7.4 Final energy production from PV panels

This investigation aims to improve the energy efficiency of the PS and, thus, achieve greater energy savings. As mentioned earlier, a simulation with a PV system installed on the PS roof was done. PV system is simulated throughout the whole year. Simulation results are presented in Figure 12.

Figure 12 shows the simulated final energy production from PV panels in the PS. The average annual electricity production from PV systems is 57795 kWh. Electricity generation is highest in June (7.01 MWh), July (7.67 MWh), and August (7.17 MWh).

On the other hand, the PV system produces the least amount of energy in November (2.35 MWh), December (1.91 MWh), and January (2.19 MWh).

Compared to Figure 3, it can be concluded that by installing PV panels on the PS roof, savings in electricity consumption of 50% can be achieved. That also means significant primary energy savings and a significant reduction of CO₂ emissions.

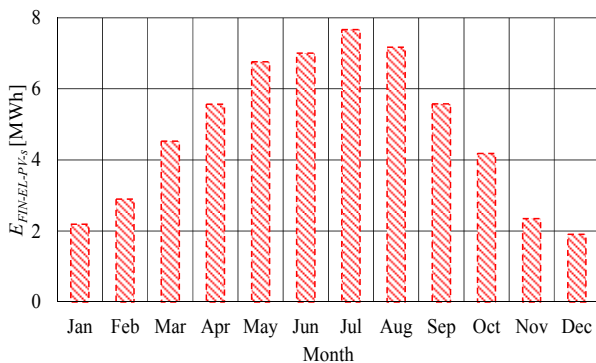

Figure 12. Simulated monthly final energy production from PV panels in the PS

7.5 Total final and primary energy consumption and gas emission in the PS without PV panels

Table 3 shows the total E_{FIN-s} , E_{PRY-s} , and e_{CO_2-s} during the year in the PS with different heating systems: the DHS, the GB, the PB, and the GSHP.

Table 3. Simulated total final and primary energy consumption and CO₂ emission for different heating systems in the PS and without PV

Indicator	Unit	DHS	GB	PB	GSHP
$E_{FIN-EL-s}$	[MWh]	87.53			194.95
$E_{FIN-H-s}$	[MWh]	530.41	524.77	548.09	-
$E_{PRY-EL-s}$	[MWh]	218.83			487.36
$E_{PRY-H-s}$	[MWh]	954.74	577.25	54.81	-
e_{CO_2-EL-s}	[t]	115.98			258.3
e_{CO_2-H-s}	[t]	315.07	115.45	14.25	-

When E_{FIN-s} are considered, the best results are achieved with the GSHP, where significantly greater energy saving is achieved (Table 3).

In this case, $E_{FIN-s}=E_{FIN-EL-s}$ in the PS is 194.95 MWh. Compared to the existing DHS ($E_{FIN-EL-s}=87.53$ MWh and $E_{FIN-H-s}=530.41$ MWh) system in the PS, the E_{FIN-s} indicator shows that the GSHP is better by 422.99 MWh (68.45%). In second place is the GB (for 5.64 MWh, or 0.91%). In the case of using the PB system, results show that the DHS is a better solution (for 17.68 MWh, or 2.86%).

The best E_{PRY-s} results in the PS are achieved with the PB (273.64 MWh). In comparison with the DHS, E_{PRY-s} savings were achieved in the amount of 899.93 MWh (76.68%). Good results are also obtained by the application of an alternative heating system with the GSHP, with which E_{PRY-s} savings of 686.21 MWh are achieved (58.47%), compared to the DHS. The worst results in terms of E_{PRY-s} were obtained by simulating the PS with the GB system. In that case, E_{PRY-s} savings were 377.49 MWh, or 32.17%, compared to the DHS.

The trend of calculated CO₂ emission in the PS is the same as the trend in the case of E_{PRY-s} . For referent PS (with the DHS), CO₂ emission is 431.05 t. For the GB, the PB, and the GSHP, CO₂ emissions were (Table 3): 231.43 t, 130.23 t, and 258.3 t, respectively. This means that an alternative heating system with the PB has the highest CO₂ emission saving (300.82 t) compared to the DHS. For the PS with the GB, the decrease in CO₂ emission is 199.62 t. In the end, for the PS with the GSHP, the decrease in CO₂ emission is 172.75 t or 40.08%.

7.6 Total final and primary energy consumption and gas emission in the PS with PV panels

Further improving PS energy efficiency by implementing PV panels gave better results regarding energy (final and primary) consumption and CO₂ emission (Table 4).

DHS and alternative heating systems, in combination with the PV power plant on the PS roof (Figure 5, Figure 12), significantly reduce E_{FIN-s} , E_{PRY-s} , and e_{CO_2-s} , as shown in Table 4.

The highest E_{FIN-s} in the PS is in the case of the PB+PV (577.82 MWh), followed by the PS with the DHS+PV (560.14 MWh). Value E_{FIN-s} is the smallest in the next two cases: the GSHP+PV (136.97 MWh) and the GB+PV (554.5 MWh), respectively.

Table 4. Simulated total final and primary energy consumption and CO₂ emission for different heating systems in the PS and with PV

Indicator	Unit	+PV			
		DHS	GB	PB	GSHP
$E_{FIN-EL-s}$	[MWh]	29.73			136.97
$E_{FIN-H-s}$	[MWh]	530.41	524.77	548.09	-
$E_{PRY-EL-s}$	[MWh]	74.33			342.43
$E_{PRY-H-s}$	[MWh]	954.74	577.25	54.81	-
e_{CO_2-EL-s}	[t]	39.4			181.49
e_{CO_2-H-s}	[t]	315.07	115.45	14.25	-

The E_{PRY-s} is the highest in the case of the DHS+PV (1029.07 MWh). For the PB+PV, the E_{PRY-s} is the smallest (129.14 MWh). Now, the GSHP+PV is in third place (342.43 MWh). PS with the GB+PV is a better solution than DHS+PV but worse than the GSHP+PV because E_{PRY-s} is 651.58 MWh.

CO₂ emissions in the PS with PV panels and different heating systems are 354.47 t (for the DHS), 154.85 t (for the GB), 53.65 t (for the PB), and 181.49 t (for the GSHP), respectively.

7.7 Multi-criteria analysis

Serbia belongs to the group of energy-inefficient countries because it does not care enough about energy consumption. Energy is consumed irrationally in all sectors, including the BS. For these reasons, improving the energy efficiency of buildings is of great importance. In that way, energy consumption can be significantly reduced, as well as the emission of harmful greenhouse gases, primarily the emission of CO₂. Also, in Serbia, little attention is paid to primary energy consumption. That is the necessary reason for implementing improvement measures for energy efficiency, to primarily reduce the consumption of primary energy and thus the emission of greenhouse gases.

In this paper, 37, an MCDM analysis is carried out to find the optimal alternative heating system that can replace the existing DHS in the PS.

Table 5. Summary of ECM criteria for MCDM analysis

ECM/Unit	Savings		
	E_{FIN-s}	E_{PRY-s}	e_{CO_2-s}
	[MWh]	[MWh]	[t]
GB	5.64	377.49	199.62
PB	-17.68	899.93	300.82
GSHP	422.99	686.21	172.75
DHS+PV	57.8	144.5	76.58
GB+PV	63.44	521.99	276.2
PB+PV	40.12	1044.43	377.4
GSHP+PV	480.97	831.14	249.56

Table 5 identifies different systems that can contribute to energy conservation ECM. First was referent the PS with the DSH, then the PS with different heating systems (the GB, the PB, and the GSHP), and after that, the PS with PV panels and different heating systems (the DHS+PV, the GB+PV, the PB+PV, and the GSHP+PV).

According to the previous discussion, the criteria and weight factors shown in Table 6 were evaluated to rank the ECM.

Table 6. The weight of importance of each criterion

Criterion / Unit	Savings [%]		
	E_{FIN-s}	E_{PRY-s}	e_{CO_2-s}
w_j	20	45	35

A normalization process was conducted for the values of each criterion. All ECM criteria have to be comparable, so it is necessary to adjust the obtained values to the same scale with the process of linear normalization.

For the criteria of CO₂ emission, where the most desirable value is the lowest one, the normalized value x_{ij} is the ratio of the minimal value of all proposed ECM and the value obtained for the given ECM. With criteria where the highest value is the most desirable (like energy savings), normalized value x_{ij} is the ratio of real value and the maximum value for all ECM. Calculated normalized values coefficients are used to rank the ECM (Tables 7-10).

Table 7. Ranking of ECM for final energy consumption

Criterion	E_{FIN-s} savings	E_{FIN-s} RANK
GB	0.0023	6
PB	-0.0074	7
GSHP	0.1759	2
DHS+PV	0.024	4
GB+PV	0.0264	3
PB+PV	0.0167	5
GSHP+PV	0.2	1

Table 8. Ranking of ECM for primary energy consumption

Criterion	E_{PRY-s} savings	E_{PRY-s} RANK
GB	0.1626	6
PB	0.3877	2
GSHP	0.2957	4
DHS+PV	0.0623	7
GB+PV	0.2249	5
PB+PV	0.45	1
GSHP+PV	0.3581	3

Table 9. Ranking of ECM for CO₂ emissions

Criterion	e_{CO_2-s} savings	e_{CO_2-s} RANK
GB	0.1851	5
PB	0.279	2
GSHP	0.1602	6
DHS+PV	0.071	7
GB+PV	0.2561	3
PB+PV	0.35	1
GSHP+PV	0.2314	4

Table 10. Final ranking of ECM

Criterion	S_i	EMC RANK
GB	0.3501	6
PB	0.6594	3
GSHP	0.6318	4
DHS+PV	0.1573	7
GB+PV	0.5074	5
PB+PV	0.8167	1
GSHP+PV	0.7895	2

The results obtained by MCDM indicated that introducing more criteria changes the choice of an alternative heating system in the PS, which was previously obtained based on the simulation results (the PS was the best solution).

Specifically, in this case, the MCDM analysis suggests the use of the PB+PV as an alternative heating system in the PS, taking into account both energy consumption (final and primary energy savings) and the reduction of CO₂ emissions.

Such findings emphasize the need to conduct multi-criteria analyses in energy audits as a single, individual parameter can never be observed. It is necessary to observe the situation in its entirety and include several influential parameters in the consideration.

8. CONCLUSION

The paper discusses the possibility of replacing the existing heating system with an alternative heating system, using simulations and MCDM (final energy consumption, primary energy consumption, and CO₂ emission).

Numerical monitoring was carried out using Google SketchUp and EnergyPlus software in a PS case study in the city of Kragujevac (Serbia). An energy model corresponding to the current state of the building's thermal envelope and the existing DHS was created for the PS. Validation of the energy model was carried out by comparing the predicted (simulated) and real (five-year sample) energy consumption for heating. Other heating systems were considered: the GB, the PB, and the GSHP. An additional RES system that would reduce energy consumption was also considered (PV panels installed on the roof of the PS). Numerical simulations were carried out in two steps: for the PS without PV panels and the PS with PV panels installed on the roof.

Simulation results for the PS without PV panels show that the best choice for an alternative heating system, in terms of final energy consumption, is the GHSP (final energy saving 422.99 MWh or 68.45%). In terms of primary energy consumption and CO₂ reduction, the best choice is the PB (with a primary energy saving of 899.93 MWh or 76.68%, and the CO₂ reduction of 300.82 t or 69.79%).

For the PS with PV panels, obtained results show the same trend as in the previous case – the best choice for an alternative heating system, in terms of final energy consumption, is the GHSP (final energy saving 480.97 MWh or 77.83%). In terms of primary energy consumption and CO₂ reduction, the best choice is the PB. This

heating system can reduce primary energy consumption by 1044.43 MWh or 89% and CO₂ emission by 377.4 t or 87.55%.

It is necessary to include and consider several influential parameters simultaneously during the energy audit. That is why MCDM was carried out, which considered both energy consumption (final and primary) and CO₂ emission. Taking into account the importance of environmental pollution and energy consumption, the result of MCMD analysis for the best alternative heating system in PS with the DHS is the PB with PV panels ($S_i=0.8167$).

Further improvement of the PS energy efficiency could be realized by installing PV panels with higher cell efficiency. Using these steps, a concept of nearly zero-net energy buildings (NZEBS) or zero-net energy buildings (ZEBs) could be achieved.

ACKNOWLEDGMENT

This investigation is a part of project TR33015 of the Ministry of Science, Technological Development and Innovation of the Republic of Serbia.

We would like to thank the Ministry of Science, Technological Development, and Innovation of the Republic of Serbia for their financial support during this investigation.

REFERENCES

- [1] Available at: https://www.c40.org/why_cities.
- [2] Ašonja, A. N. and Rajković, J. Z.: An energy consumption analysis on public applications in the city of Novi Sad, Applied Engineering Letters, Vol. 2, No. 3, pp. 115-120, 2017.
- [3] Available at: <http://www.aarhus.org.rs/projekti/connect/program-energetske-efikasnosti-grada-kragujevac-za-period-2018-2020/>.
- [4] Dong, Y., Zhu, L., Li, S., Wollensak, M.: Optimal design of building openings to reduce the risk of indoor respiratory epidemic infections, Building Simulation, Vol. -, No. -, pp. 1-14, 2022.
- [5] Dai, H. and Zhao, B.: Association of the infection probability of COVID-19 with ventilation rates in confined spaces, Building Simulation, Vol. 13, No. -, pp. 1321-1327, 2020.
- [6] Kazagic, A., Merzic, A., Redzic, E. and Tresnjo, D.: Optimization of modular district heating solution based on CHP and RES-demonstration case of the municipality of Visoko, Energy, Vol. 181, No. -, pp. 56-65, 2019.
- [7] Dainese, C., Faè, M., Gambarotta, A., Morini, M., Premoli, M., Randazzo, G., Rossi, M., Ravati, M. and Saletti, C.: Development and application of a predictive controller to a mini district heating network fed by a biomass boiler, Energy Procedia, Vol. 159, No. -, pp. 48-53, 2019.
- [8] De Lorenzi, A., Gambarotta, A., Morini, M., Rossi, M., Saletti, C.: Setup and testing of smart controllers for small-scale district heating networks: An integrated framework, Energy, Vol. 205, No. -, pp. 118054, 2020.

- [9] Rosato, A., Ciervo, A., Ciampi, G., Sibilio, S.: Effects of solar field design on the energy, environmental and economic performance of a solar district heating network serving Italian residential and school buildings, *Renewable Energy*, Vol. 143, No. -, pp. 596-610, 2019.
- [10] Stocker, E., Tschurtschenthaler, M. and Schrott, L.: Cost-optimal renovation and energy performance: Evidence from existing school buildings in the Alps, *Energy and Buildings*, Vol. 100, No. -, pp. 20-26, 2015.
- [11] Morshed, T.: An investigation of naturally ventilated teaching spaces with windcatchers in secondary school where site is constrained by noise and air pollution, *Building Simulation*, Vol. 7, No. 5, pp. 547-561, 2014.
- [12] Vaskovic, S., Gvero, P., Medakovic, V., Halilovic, V.: Feasibility study for replacement heating system on natural gas with pellet boilers at primary school "St. Sava" in East Sarajevo, *Annals of the Faculty of Engineering Hunedoara*, Vol. 14, No. 3, pp. 255-259, 2016.
- [13] Busato, F., Lazzarin, R. M., Noro, M.: Multisource heat pump system from design to operation: The case study of a new school building, *International Journal of Low-Carbon Technologies*, Vol. 8, No. 2, pp. 88-94, 2013.
- [14] Lazzarin, R., Noro, M.: Photovoltaic/Thermal (PV/T)/ground dual-source heat pump: Optimum energy and economic sizing based on performance analysis, *Energy and Buildings*, Vol. 211, No. -, pp. 109800, 2020.
- [15] Busato, F., Lazzarin, R. M., Noro, M.: Two years of recorded data for a multisource heat pump system: A performance analysis, *Applied Thermal Engineering*, Vol. 57, No. 1-2, pp. 39-47, 2013.
- [16] Wang, Y., Zhao, F. Y., Kuckelkorn, J., Spliethoff, H., Rank, E.: School building energy performance and classroom air environment implemented with the heat recovery heat pump and displacement ventilation system, *Applied Energy*, Vol. 114, No. -, pp. 58-68, 2014.
- [17] Bendaikha, W., Larbi, S., Bouziane, M.: Feasibility study of hybrid fuel cell and geothermal heat pump used for air conditioning in Algeria, *International Journal of Hydrogen Energy*, Vol. 36, No. 6, pp. 4253-4261, 2011.
- [18] Androulakis, N. D., Armen, K. G., Bozis, D. A., and Papakostas, K. T.: Simulation of the thermal performance of a hybrid solar-assisted ground-source heat pump system in a school building, *International Journal of Sustainable Energy*, Vol. 37, No. 4, pp. 311-324, 2018.
- [19] Martin, M. A., Durfee, D. J., Hughes, P. J.: Comparing maintenance costs of geothermal heat pump systems with other HVAC systems in Lincoln Public Schools: Repair, service, and corrective actions, in: *Proceedings of the ASHRAE Annual Meeting*, 19-23.06.1999, Seattle, pp. 1-15.
- [20] Allaerts, K., Al Koussa, J., Desmedt, J., Salenbien, R.: Improving the energy efficiency of ground-source heat pump systems in heating dominated school buildings: A case study in Belgium, *Energy and Buildings*, Vol. 138, No. -, pp. 559-568, 2017.
- [21] Economou, A.: Photovoltaic systems in school units of Greece and their consequences, *Renewable and Sustainable Energy Reviews*, Vol. 15, No. 1, pp. 881-885, 2011.
- [22] Shaari, S., Bowman, N.: Photovoltaics in buildings: A case study for rural England and Malaysia, *Renewable Energy*, Vol. 15, No. 1-4, pp. 558-561, 1998.
- [23] Yilmaz, S., Binici, H. and Ozcalik, H. R.: Energy supply in a green school via a photovoltaic-thermal power system, *Renewable and Sustainable Energy Reviews*, Vol. 57, No. -, pp. 713-720, 2016.
- [24] Bilir, L. and Yildirim, N.: Photovoltaic system assessment for a school building, *International Journal of Hydrogen Energy*, Vol. 42, No. 28, pp. 17856-17868, 2017.
- [25] Cholakkal, L.: *Cost-benefit analysis of a building integrated photovoltaic roofing system for a school located in Blacksburg, Virginia*, PhD thesis, Faculty of the Virginia Polytechnic Institute, State University, Virginia, 2006.
- [26] Harkouss, F., Fardoun, F., Biwole, P. H.: Optimization approaches and climates investigations in NZEB-A review, *Building Simulation*, Vol. 11, No. -, pp. 923-952, 2018.
- [27] Lou, S., Tsang, E. K., Li, D. H., Lee, E. W., Lam, J. C.: Towards zero energy school building designs in Hong Kong, *Energy Procedia*, Vol. 105, No. -, pp. 182-187, 2017.
- [28] Attia, S., Shadmanfar, N. and Ricci, F.: Developing two benchmark models for nearly zero energy schools, *Applied Energy*, Vol. 263, No. -, pp. 114614, 2020.
- [29] Moazzen, N., Ashrafiyan, T., Yilmaz, Z., Karagüler, M. E.: A multi-criteria approach to affordable energy-efficient retrofit of primary school buildings, *Applied Energy*, Vol. 268, No. -, pp. 115046, 2020.
- [30] Gojak, M., Ljubinac, F., Banjac, M.: Simulation of Solar Water Heating, *FME Transactions*, Vol. 47, No. 1, pp. 1-6, 2019.
- [31] Stojićević, M., Jelić, Z., Obradović, M., Obradović, R., Marinescu, G. C.: Designs of Solar Concentrators, *FME Transactions*, Vol. 47, No. 2, pp. 273-278, 2019.
- [32] Naveed, S. S., Jena, S., Kumar, S. V., Anil, K. E.: Performance investigation of multi-stage hydrogen-based sorption heat pump, *FME Transactions*, Vol. 49, No. 1, pp. 121-127, 2021.
- [33] Kavade, R. K., Ghanegaonkar, P. M.: Performance analysis of small scale variable pitch vertical axis wind turbine, *FME Transactions*, Vol. 50, No. 2, pp. 322-330, 2022.

- [34] Available at: http://www.ingkomora.org.rs/strucni-ispiti/download/ee/PRAVILNIK_O_EEZ_za%20obuku.pdf.
- [35] Skerlić, J.: *Optimization of the solar collectors` position in houses with net-zero energy consumption*, PhD thesis, Faculty of Engineering University of Kragujevac, University of Kragujevac, Kragujevac, 2015.
- [36] Available at: <https://www.prostarsolar.net/product-details/prostar-72-solar-cells-monocrystalline-340w-solar-panel-cost>.
- [37] Available at: <https://energyplus.net/>.
- [38] Kumar, A., Sah, B., Singh, A. R., Deng, Y., He, X., Kumar, P., Bansal, R. C.: A review of multi-criteria decision making (MCDM) towards sustainable renewable energy development, *Renewable and Sustainable Energy Reviews*, Vol. 69, No. -, pp. 596-609, 2017.

NOMENCLATURE

A	Area, [m ²]
COP	Coefficient of performance, [-]
E	Energy consumption, [MWh]
e	Emission CO ₂ , [t]
f	Fraction, [-]
I	Total solar radiation, [MWh/m ²]
i	Number, [-]
K	Primary conversion multiplier, [-]
m	Specific emission CO ₂ , [kg/kWh]
NOP	Number of proposed ECM, [-]
n	Number of criteria, [-]
P	Electric power, [W]
R^2	Determination coefficient, [-]
S_i	WSM score, [-]
t	Temperature, [°C]
U	Heat transfer coefficient, [W/m ² K]
w_j	Weight of j criterion performance, [%]
x_{ij}	Normalized value of i ECM in terms of j criterion, [-]

Greek symbols

β	The slope angle of the PV panel, [deg]
δ	Thickness, [cm]
η	Efficiency, [-]
τ	Time [s]

Subscript

AIR	Air
CV	Control valve
spec	Specific
EE	Electric equipment
FIN	Final
H	Heating
INV	Inverter
L	Lighting
PN	Pipe network
PRY	Primary
r	Real
s	Simulated

Abbreviations

BB	Biomass boiler
BIPV	Building-integrated photovoltaic
BS	Building sector
CEP	City energy plant
CO ₂	Carbon dioxide
CP	Circulation pump
DHS	District heating system
ECM	Energy conversation measure
EI	Educational institution
GB	Gas boiler
GSHP	Ground source heat pump
HRS	Heat recovery system
HS	High school
HVAC	Heating, ventilation, and air conditioning
MCDM	Multi-criteria decision-making
NZEB	Nearly zero-net energy building
PB	Pellet boiler
PBS	Public building sector
PHE	Plate heat exchanger
PS	Primary school
PV	Photovoltaic
PVT	Photovoltaic thermal
RAD	Radiator heater
RB	Residential building
RES	Renewable energy sources
SB	School building
SH	Sports hall
SS	Secondary school
VGB	Vertical geothermal boreholes
WSM	Weighted Sum Model
ZEB	Zero-net energy building

НУМЕРИЧКА И ВИШЕКРИТЕРИЈУМСКА АНАЛИЗА ЕНЕРГЕТСКИХ ТОКОВА У ОСНОВНОЈ ШКОЛИ НА ТЕРИТОРИЈИ ГРАДА КРАГУЈЕВЦА

А. Нешовић, Д. Николић, А. Радојевић

У овом раду изложена је метода на бази нумеричке и вишекритеријумске анализе енергетских токова у основној школи на територији града Крагујевца. Прво је креиран модел постојеће школске зграде са системом даљинског грејања. Потом су анализирани алтернативни системи грејања (гасни котлоу, котлоу на пелет и геотермална топлотна пумпа) у циљу остваривања енергетских уштеда. Различити типови система грејања симулирани су са фотонапонским панелима, као и без њих. Google SketchUp је коришћен за моделирање зграде, а EnergyPlus за прорачун енергетских токова у реалним временским условима. Резултати су показали да котлови на пелет у комбинацији са фотонапонским панелима могу редуковати потрошњу примарне енергије за 89%, а емисију CO₂ за 87,55%. За геотермалну топлотну пумпу са фотонапонским панелима, потроња финалне енергије смањила би се за 77,83%, примарне енергије за 70,82% а емисија CO₂ за 57,90%. Користећи нумеричку и вишекритеријумску анализу, идеја аутора је била да се постојећа зграда јавне намене приближи концепту нултих енергетских зграда, а град концепту одрживог развоја.