

Methodology of testing guided-type fall arresters with rail-based rigid anchor lines

Milan Bižić^{1*}, Dragan Petrović¹

¹ University of Kragujevac, Faculty of Mechanical and Civil Engineering in Kraljevo, Kraljevo, Serbia

ARTICLE INFO

* **Correspondence:** bizic.m@mfkv.kg.ac.rs

DOI: 10.5937/engtoday2500005B

UDC: 621(497.11)

ISSN: 2812-9474

Article history: Received 24 April 2025; Revised 20 May 2025; Accepted 26 May 2025

ABSTRACT

Guided-type fall arresters with a rigid anchor line made of rail are among the most effective ways of fall protection from height. Their primary role is to ensure the user's safe movement during climbing and to protect them in the event of a sudden fall. Given that the functionality and reliability of this personal fall protection equipment directly impact the user's safety, the requirements for its quality are very rigorous. These requirements are precisely defined in European standards. Therefore, the aim of this paper is to provide a systematic overview of the methodology of testing of guided-type fall arresters with a rigid anchor line made of rail, in accordance with standard EN 353-1. This methodology is developed by the Laboratory for Railway Engineering and Structures Testing at the Faculty of Mechanical and Civil Engineering in Kraljevo, University of Kragujevac, Serbia. The paper analyzes the requirements for the physical, geometric, and mechanical characteristics of guided-type fall arresters and rigid anchor lines made of rail. Special attention is given to the procedures for performing both static and dynamic tests. The results of the conducted research provide a basis for assessing the potential for developing and manufacturing this type of personal fall protection equipment for the international market, while also contributing to ongoing efforts to improve its quality and safety by offering insights relevant to global production and certification processes.

KEYWORDS

Guided-type fall arrester, Fall arrester testing, Fall protection system, Rigid anchor line, Rail anchor line, EN 353-1.

1. INTRODUCTION

Work at height is one of the most hazardous aspects of industrial and construction activities, with falls from height remaining among the leading causes of serious injuries and fatalities. Therefore, the use of personal fall protection equipment is essential to ensure the safety of workers. Among these systems, guided-type fall arresters with a rigid anchor line represent one of the most effective solutions, providing reliable fall protection and ergonomic freedom of movement of users along high-elevation structures [1–3]. A particularly important aspect of fall protection is related to the regular or emergency maintenance of various types of structures at high heights. Although user safety in these cases has significantly improved in recent decades, falls from heights are still very common and result in large percent with fatal outcome [4]. In this context, the use of personal fall protection equipment is especially significant in the maintenance of transmission towers or poles, regard the dangers associated with working at height under such conditions. Workers involved in the installation, maintenance and inspection of transmission lines are frequently exposed to significant risks due to the height of the towers or poles and demanding working environment. The deployment of reliable fall protection equipment is essential for preventing fatal accidents and ensuring the safety of

workers who often operate in remote and high-risk locations. Transmission poles and towers are often located in hard-to-reach areas, which further complicates the task of ensuring worker safety. Considering the potential for falls and the remoteness of these work sites, appropriate fall protection equipment is crucial for minimizing the risk of serious injury. The adoption of advanced fall protection systems, such as guided-type fall arresters with a rigid anchor line, not only improves worker safety, but also increases operational efficiency by allowing workers to concentrate on their tasks without the constant worry of a possible fall [5]. Precisely due to the aforementioned risks and the need for reliable protection, fall protection equipment, i.e. guided-type fall arresters with a rigid anchor line, has been accurately standardized by the European standard EN 353-1 [6]. The purpose of this standard is to ensure appropriate quality of fall protection equipment and to provide a high level of user safety in accordance with the requirements for protecting the life and health of workers at height.

Existing research in the field of fall protection systems, i.e. the guided-type fall arresters with a rigid anchor line, has mainly focused on developing new solutions and continuously improving system components [7–12]. The studies are primarily addressed the optimization of device functionality, the enhancement of ergonomic features, and the use of advanced materials to increase durability and reliability of structural elements of fall protection system. Significant attention has also been given to improving user mobility and comfort during vertical movement, as well as to reducing the impact forces transmitted to the user in the event of a fall. However, despite technological advances, there is still a need for systematic testing methodologies that ensure compliance with standard requirements in real operating conditions.

Accordingly, the aim of this paper is to provide a systematic overview of the methodology of testing of guided-type fall arresters with a rigid anchor line in accordance with standard EN 353-1, as a basis for analyzing the feasibility of development and manufacturing this type of personal fall protection equipment for the international market.

2. CONSTRUCTION

The typical construction of the guided-type fall arrester with rigid anchor line made of rail is shown in Fig. 1. It is composed of: 1 – rigid anchor line (rail), 2 – joint, 3 – bracket, 4 – stopper A or B type, 5 – stopper A type, 6 – guided-type fall arrester (hereinafter referred to as GTFA), 7 – energy dissipating element and 8 – connecting element. An example of such a system of Vertiqal Engineering production is shown in Fig. 2.

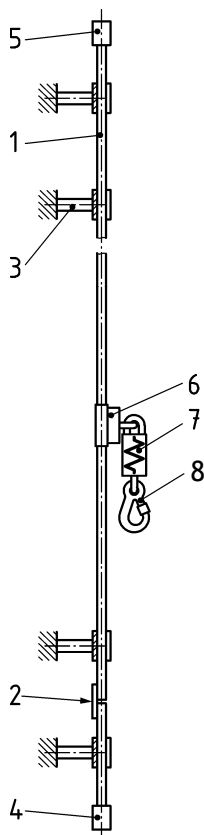

Figure 1: Schematic representation of construction of guided-type fall arrester with rigid anchor line made of rail [6]



Figure 2: Example of construction of guided-type fall arrester with rigid anchor line made of rail (Vertiqal Engineering production) [13]

The rigid anchor line, i.e., the rail, is equipped with terminations, brackets, joints, connectors, energy-dissipating elements and stop devices, intended for use with a GTFA. An energy-dissipating element is a component of a fall protection system designed to absorb and dissipate the kinetic energy generated during a fall from height. A GTFA is a device with a self-locking function, a guiding mechanism, and a connecting element for attachment to the appropriate point on a full body harness. It accompanies the user during both upward and downward movement without requiring manual adjustment, and it locks automatically on the rigid anchor line (rail) in the event of a fall. The connecting element is a part of the GTFA that forms the link between the fall arrester and the front attachment point of a full body harness conforming to EN 361 [14].

Stoppers are fitted to the rigid anchor line to prevent the GTFA from unintentionally passing a specific point or becoming detached from the rigid anchor line. Stopper A type is a device designed to prevent the GTFA from unintentionally passing a specific point or becoming detached from the rigid anchor line during ascent or descent. Stopper B type is a device designed to prevent the GTFA from unintentionally passing a specific point or becoming detached from the rigid anchor line in the event of a fall. The bracket serves to attach the rigid anchor line (rail) to an appropriate structure or object, while the joint serves to connect two or more sections of the rigid anchor line (two or more rails).

A schematic illustration of installation configurations of the rigid anchor line (rail), in accordance with EN 353-1, is shown in Fig. 3. In relation to the vertical direction (2), the rail (1) can be inclined in three different directions, forming a zone of possible configurations (3). In this case, the values of angles α , β , and γ can range from 0 to 15 degrees.

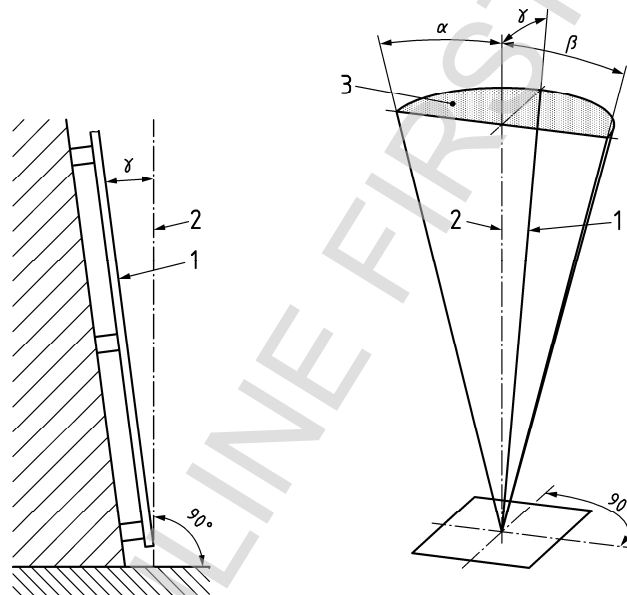

Figure 3: A schematic illustration of installation configurations of the rigid anchor line (rail) [6]

The GTFA must be designed to be removable from the rail – however, the entire system must prevent unintentional separation of the GTFA from the rail. If the GTFA is removable by the user at any point other than the ends of the rail, the GTFA or the rail must be designed in such a way that detachment is only possible through at least two consecutive, deliberate manual actions. The GTFA, including the rail, must incorporate a feature that prevents incorrect orientation when being fitted or attached to the rail. The connecting element must be permanently attached to the GTFA and must comply with the requirements of EN 362 [15]. When connected to the rail, the GTFA must be capable of following the user's movement in both upward and downward directions without requiring manual intervention. If the GTFA includes a non-metallic component, this component, including its end terminations, must be protected against abrasion. Stoppers that can be opened must be operable only through deliberate manual action, must be self-closing, and must not be removable from the rail.

Connecting or energy-dissipating elements made from fibre ropes, webbings, or sewing threads must be manufactured from virgin filament or multifilament synthetic fibres appropriate for their intended application. The breaking tenacity of these synthetic fibres must be known to be at least 0.6 N/tex. Materials that may come into contact with the user's skin must not be known to cause irritation or sensitization when used as intended. The exposed edges or corners of components must be relieved either with a radius of at least 0.5 mm or a chamfer of at least 0.5 mm × 45° [6].

3. FIRST-STAGE TESTS

The first-stage tests of the GTFA with a rigid rail anchor line made of rail, are shown in Tables 1–3. These tests are part of the test program developed by the Laboratory for Railway Engineering and Structures Testing at the Faculty of Mechanical and Civil Engineering in Kraljevo, University of Kragujevac, Serbia, in accordance with EN 353-1.

Table 1: Preliminary checks and verifications of test samples

Preliminary checks and verifications
1.1. Visual inspection and verification of the test samples
1.2. Check and verification of materials (e.g., material certificates)
1.3. Review and verification of the manufacturer's technical documentation
1.4. Check of the presence of materials that may cause irritating or sensitizing effects upon contact with the user's skin
1.5. Check of the presence of sharp edges or corners — specifically, those with a radius less than 0.5 mm or a chamfer smaller than 0.5 mm × 45°

Table 2: Checks on test sample that must include at least two maximum spans between rails, as well as joint and stoppers

Checks and verification
1.6. Verification of whether the GTFA is detachable from the rail
1.7. Verification of whether the equipment is designed to prevent unintentional detachment of the GTFA from the rail
1.8. If the GTFA can be removed from the rail and beyond the rail ends — verification of whether the equipment is designed so that this can only be done with at least two consecutive intentional manual actions
1.9. Verification of whether the equipment is designed to prevent incorrect orientation of the GTFA when placing it on the rail
1.10. Verification of whether the attachment elements are permanently secured to the GTFA
1.11. If the GTFA has non-metallic energy-absorbing elements – verification of whether these elements are protected from abrasion
1.12. Verification of whether the opening barriers are designed to be self-closing and that their opening can only be performed by intentional manual action
1.13. Verification of whether the connectors attached to the GTFA's attachment element meet the requirements of standard EN 362

Table 3: Verification on test sample that must be mounted on ladder

Verification
1.14. Verification that the GTFA follows the user smoothly while ascending and descending along the rail, without any manual intervention
- The climbing and descending test is performed by two persons of different heights and weights, ranging from 160 cm to 190 cm in height and from 60 kg to 95 kg in weight
- Both persons must wear light clothing
- Each person must wear a full body harness conforming to EN 361, equipped with a front fall-arrest attachment point
- If the harness includes multiple front attachment points, the test is performed for each attachment point
- Both persons must ascend and descend along the entire length of the rail
- If the rail is designed to be mounted in different orientations - inclined forward or sideways - the test is repeated for each of these configurations

4. STATIC TESTS

After the first-stage testing, static tests are conducted in the appropriate order. Firstly, the testing of the non-metallic energy-absorbing element (if present in the equipment) is carried out. Subsequently, the GTFA with a rail must be tested under vertical loading (Fig. 4). The test sample, including the GTFA, is installed in the test stand in accordance with the manufacturer's assembly instructions. The test stand must comply with the standard EN 364 [16]. The test sample includes the maximum allowed spans between brackets as permitted by the manufacturer. If the manufacturer allows a joint at the midpoint of the span between brackets, it must be included in the test sample. A static load of 15^{+1.0} kN is applied in the direction of the load in the event of a fall, and it is maintained for a duration of

$3^{+0.25}$ min. The load is applied in two cases – when the GTFA is positioned at the maximum distance above the bracket immediately below the stopper, and when the GTFA is positioned at the midpoint of the span between brackets. The GTFA and rail must be capable of withstanding the applied load.

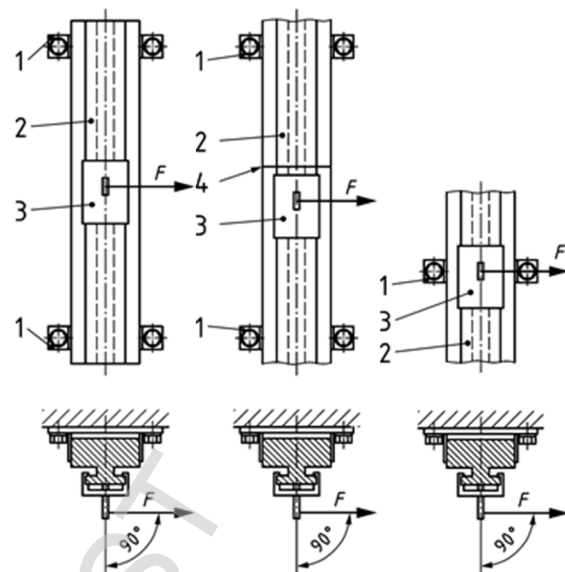
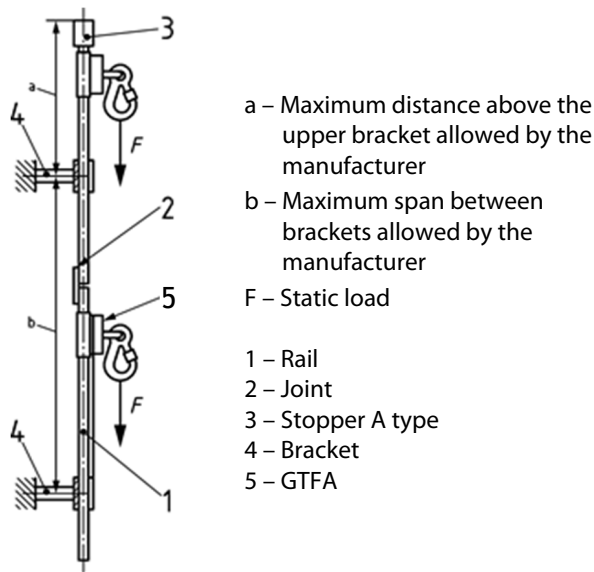

Figure 4: Scheme of static testing under vertical load [6]

Figure 5: Scheme of static testing under lateral load [6]

For testing in the lateral direction, the test sample mounting and spans are identical to those in the previous case. The GTFA is positioned between two brackets at the midpoint of the maximum span permitted by the manufacturer (Fig. 5). A horizontal static load of $1^{+0.2}$ kN is applied to the attachment element of the GTFA. This load is applied for a duration of $3^{+0.25}$ min. The test is repeated when the GTFA is positioned on the joint, as well as when it is positioned on the bracket. During this test, there must be no separation of the GTFA from the rail, and no permanent deformation of the rail. Deformations of the brackets are permitted, provided that the GTFA can move up and down without manual intervention.

In testing stopper A type, the GTFA is placed in the unlocked position and brought into contact with stopper A type (Fig. 6). A static load of $2^{+0.2}$ kN is applied to the attachment element of the GTFA in the directions for which the manufacturer has specified the use of stopper A type. This load is applied for a duration of $3^{+0.25}$ min. For the stopper B type, a static load of $12^{+1.0}$ kN is applied to the attachment element of the GTFA, and it is applied for a duration of $3^{+0.25}$ min (Fig. 7). The both stoppers must withstand the applied load, with permanent deformations allowed, but without failure.

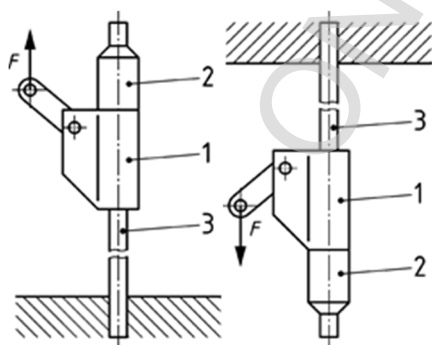

Figure 6: Scheme of static testing of stopper A type [6]

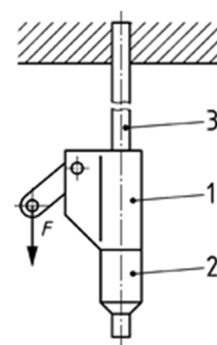

Figure 7: Scheme of static testing of stopper B type [6]

5. DYNAMIC TESTS

For dynamic testing, rigid steel test masses corresponding to the minimum and maximum declared loads are used, and they must have identical diameters and eyelet positions. Additionally, rigid steel test masses of $100^{\pm 1}$ kg and $150^{\pm 1}$ kg are required, each equipped with secure attachment points using eyelets. These masses must have a nominal diameter of 200 mm. One eyelet must be positioned at the center, while the other may be placed closer to the edge of the test mass, but no less than 25 mm from the end. Protective equipment may be installed to prevent damage to the test mass or rail, provided it does not affect the test results.

For basic dynamic testing, the rail is installed in a vertical position with a tolerance of $\pm 1^\circ$, using the maximum span lengths permitted by the manufacturer (Fig. 8). The GTFA is mounted on the rail and connected to the force transducer via its attachment element. The force transducer is then connected to the rigid test mass of 100 kg, using the eyelet located near the edge of the test mass. Through an appropriate connector, the attachment element of the GTFA is linked to a quick-release device. The test mass is raised so that the GTFA is positioned no more than 300 mm below the upper bracket. It must be ensured that the attachment element of the GTFA is in the highest possible position and that the GTFA is in the unlocked state. If the rail includes openings, teeth, or similar features, the GTFA is positioned directly below one of them, and no more than 300 mm below the upper bracket. The test mass is positioned at a horizontal distance of 300 mm from the rail. After these preparations, the test mass is released without initial velocity, and the maximum force F_{max} generated during the activation (locking) and arresting phase of the GTFA is measured and recorded. After the test mass comes to a complete stop and stabilizes, the displacement H_{AD} is measured, representing the distance between the initial and final positions of the test mass attachment point. If the manufacturer allows the rail to be installed at the ladder ends (not only at the center), the test is repeated with the maximum lateral rail offset from the ladder center as permitted by the manufacturer. The maximum force F_{max} generated during the activation (locking) and arresting phase of the GTFA must not exceed 6 kN. During this basic dynamic testing, test mass must not come into contact with the ground and the displacement H_{AD} must not exceed 1 m.

During cold-state dynamic testing, the rail is installed vertically with a tolerance of $\pm 1^\circ$, using the maximum spans permitted by the manufacturer (Fig. 9). The GTFA is exposed for at least 4 hours to the lowest temperature permitted by the manufacturer, which must not be lower than -30^{-2}°C . After this period, the GTFA is mounted on the rail and positioned at a maximum distance of 300 mm from the upper bracket. As in previous basic dynamic testing, the attachment element of the GTFA is connected to the eyelet of the test mass located near its edge. The quick-release device is connected to the eyelet positioned at the center of the test mass. The 100 kg test mass is raised so that the GTFA reaches a position no more than 300 mm below the upper bracket. It must be ensured that the attachment element of the GTFA is in the highest possible position and that the GTFA is in the unlocked state. If the rail has openings, teeth, or similar features, the GTFA is positioned directly below one of them, and no more than 300 mm below the upper bracket. The test mass must be placed at a horizontal distance of 300 mm from the rail. All of the above steps must be completed within 90 seconds after removing the GTFA from the cooling chamber, within which time the test mass is released without initial velocity. Once the test mass comes to a complete stop and stabilizes, the following are measured: H_{AD} – the distance between the initial and final positions of the attachment point of the test mass, and H_{LD} – the distance between the initial and final positions of the GTFA. During this testing, the test mass must not come into contact with the ground, the distance H_{AD} must not exceed 1 m or the distance H_{LD} must not exceed 0.5 m.

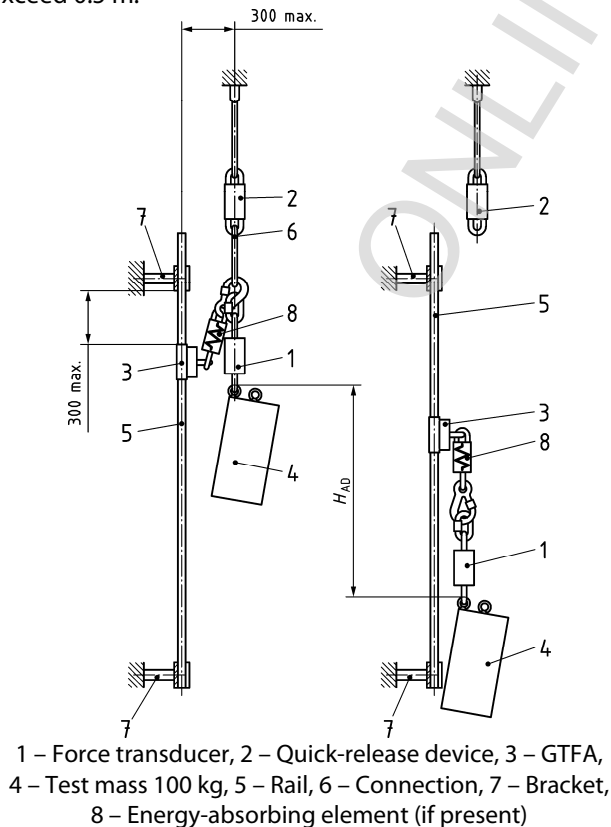

Figure 8: Scheme of basic dynamic testing [6]

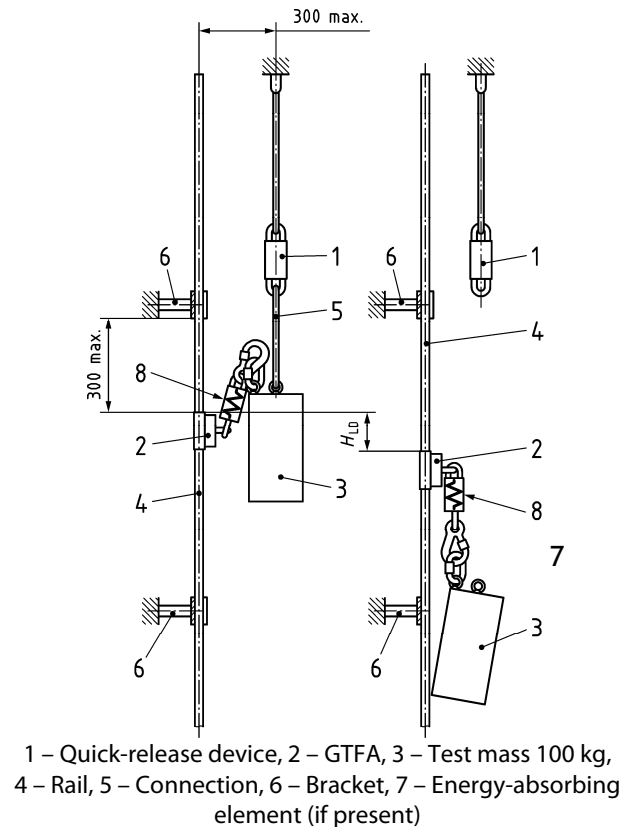
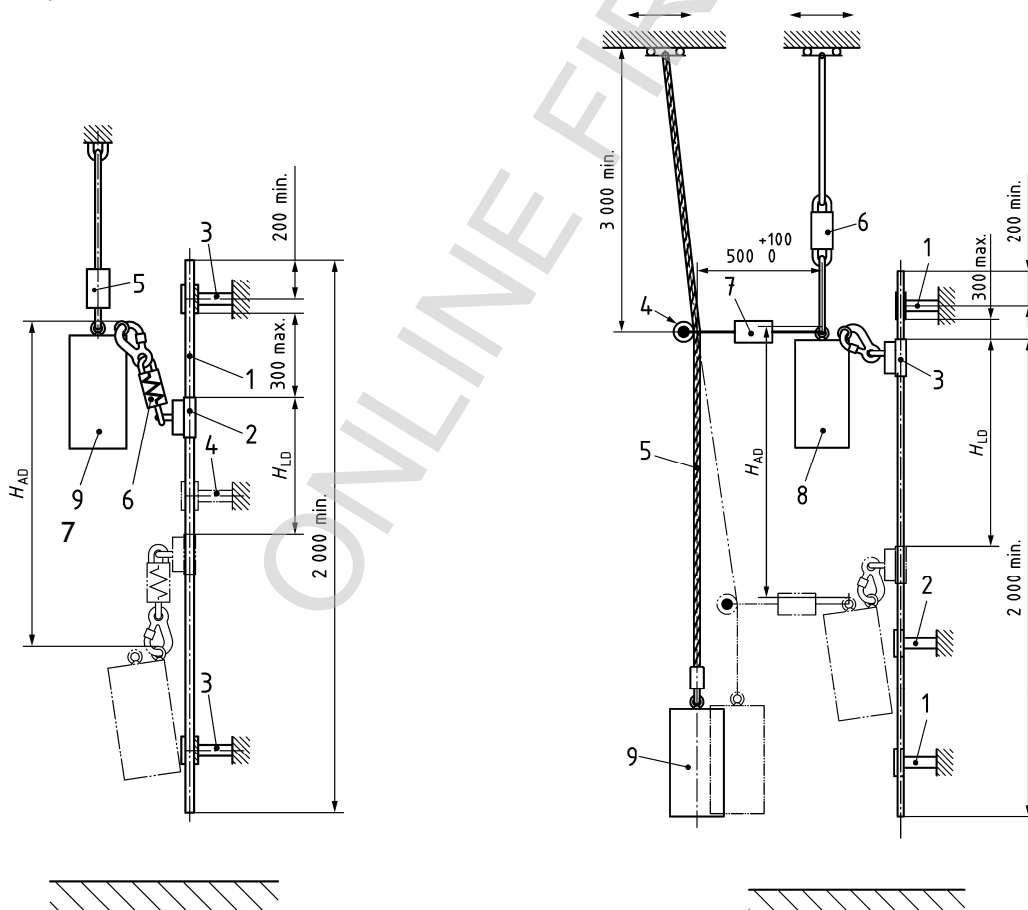

Figure 9: Scheme of cold-state dynamic testing [6]

During testing of functionality at the minimum distance from the rail, the rail is installed in a vertical position with a tolerance of $\pm 1^\circ$, and its length must be at least 2 m (Fig. 10). The test mass corresponding to the minimum declared load (± 1 kg) is attached to the quick-release device via its central eyelet. The attachment element of the GTFA is connected to the eyelet of the test mass located near its edge. The test mass is raised vertically in the same plane as the rail, with the GTFA raised to the maximum height allowed by the attachment element. When the GTFA is unlocked, the test mass must touch the GTFA without changing its position on the rail. The position of the GTFA on the rail must be such that the distance between its top and the bracket is no more than 300 mm. If the rail has openings, teeth, etc., the GTFA is positioned directly below one of them, at a maximum distance of 300 mm below the upper bracket. The test mass is released without initial velocity and after it comes to a complete stop and stabilizes, the following measurements are taken: H_{AD} – the distance between the initial and final positions of the test mass attachment point, and H_{LD} – the distance between the initial and final positions of the GTFA. The same test is repeated with a test mass corresponding to the maximum declared load (± 1 kg), but which is no less than $100^{\pm 1}$ kg. The test mass must not come into contact with the ground, the distance H_{AD} must not exceed 1 m or the distance H_{LD} must not exceed 0.5 m.

Functionality testing during a backward fall is one of the most important tests of GTFA with rigid anchor line made of rail (Fig. 11). The guiding rope used in the test must be a steel wire rope with a nominal diameter of 8 mm and must be positioned vertically. The distance between the suspension point of the steel rope and the initial position of the GTFA in the test must be at least 3 m. The mass suspended on the steel rope must be $150^{\pm 1}$ kg. The length of the horizontal connection between the steel rope and the test mass, including the force transducer and the pulling system, must be 500^{+100} mm, measured from the centerline of the rope to the point of contact at the central eyelet of the test mass. The mass of horizontal connection must be less than 1 kg. The rope pulling system must be compatible with and inseparable from the steel rope, and its diameter must be $40^{\pm 10}$ mm. The rail is installed vertically with a tolerance of $\pm 1^\circ$, and the test mass corresponding to the minimum declared load (± 1 kg) is connected via its central eyelet to the quick-release device.



1 – Rail, 2 – GTFA, 3 – Bracket, 4 – Additional bracket (depending on manufacturer's instructions), 5 – Quick-release device, 6 – Energy absorption element (if present), 7 – Test mass (minimum and maximum)

Figure 10: Scheme of functionality testing at minimum distance from rail [6]

1 – Bracket, 2 – Additional bracket (depending on manufacturer's instructions), 3 – GTFA, 4 – Rope pulling system, 5 – Guiding rope (steel rope), 6 – Quick-Release Device, 7 – Horizontal Link + Force Transducer, 8 – Test Mass (Minimum and Maximum), 9 – Mass 150 kg

Figure 11: Scheme of functionality testing at fall backward [6]

The attachment element of the GTFA is connected to the eyelet of the test mass located near its edge. The test mass is raised vertically so that the attachment element of the GTFA reaches a horizontal or higher position, with the GTFA in the unlocked state. The position of the GTFA on the rail must be such that the distance between its top and the bracket does not exceed 300 mm. If the rail has openings, teeth, or similar features, the GTFA is positioned directly below one of them, and no more than 300 mm below the upper bracket. One end of the horizontal connection with the force transducer is connected to the central eyelet of the test mass, and the other end to the steel rope pulling system. The steel rope with the attached 150 kg mass is pulled laterally until a force of 150^{+10} N is achieved in the horizontal connection. The test mass is released without initial velocity and after it comes to a complete stop and stabilizes, the following measurements are taken: H_{AD} – the distance between the initial and final positions of the test mass attachment point, and H_{LD} – the distance between the initial and final positions of the GTFA. The test is repeated using a test mass corresponding to the maximum declared load (± 1 kg), but not less than $100^{\pm 1}$ kg. During these tests, the test mass must not come into contact with the ground, the distance H_{AD} must not exceed 1 m or the distance H_{LD} must not exceed 0.5 m.

During functionality testing at fall on side, the rail is installed in a vertical position with a tolerance of $\pm 1^\circ$, and its length is minimum 2 meters (Fig. 12). The GTFA's attachment element is connected to the test mass eyelet located near the edge via an additional connector, ensuring a distance between them of $210^{\pm 5}$ mm. The test is conducted only with the maximum declared test mass, which must not be less than $100^{\pm 1}$ kg. The quick-release device is connected to the central eye of the test mass. The test mass is lifted and moved sideways to the furthest possible distance from the rail, with the GTFA remaining unlocked. The position of the GTFA on the rail must be such that the distance between its top end and the bracket is a maximum of 300 mm. If the rail includes holes, teeth, or similar features, the GTFA is positioned immediately below one of them, at a distance no greater than 300 mm below the upper bracket.

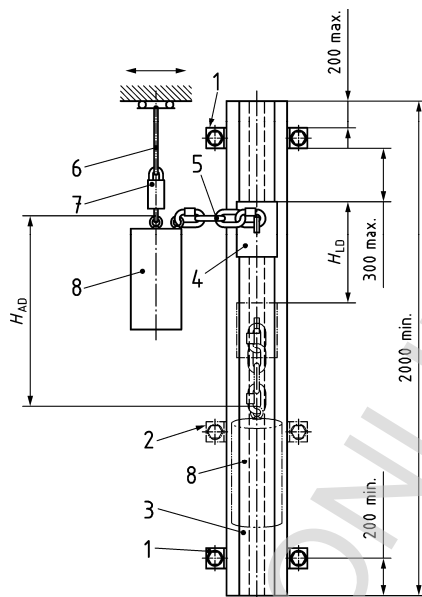

1 – Bracket, 2 – Additional bracket (depending on manufacturer's instructions), 3 – Rail, 4 – GTFA, 5 – Additional link (210 mm), 6 – Connection, 7 – Quick-release device, 8 – Test mass (maximum)

Figure 12: Scheme of functionality testing at fall on side [6]

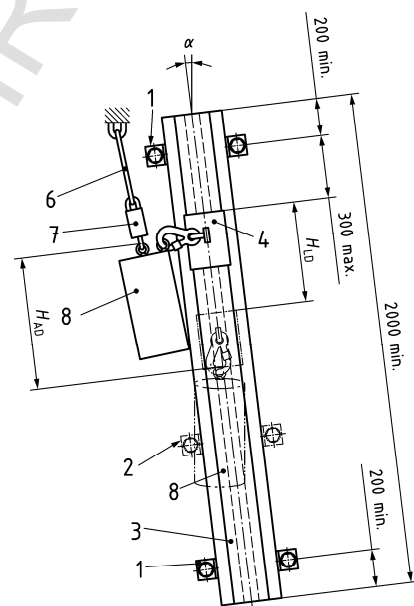

1 – Bracket, 2 – Additional bracket (depending on manufacturer's instructions), 3 – Rail, 4 – GTFA, 5 – Link element with energy absorber (if applicable), 6 – Connection, 7 – Quick-release device, 8 – Test mass (minimum and maximum)

Figure 13: Scheme of functionality testing with laterally inclined rail [6]

The test mass is released without any initial velocity and after the fall is arrested and the test mass is stabilized, the following are measured: H_{AD} – the distance between the initial and final positions of the test mass attachment point and H_{LD} – the distance between the initial and final positions of the GTFA. The test is performed for all different configurations that may lead to lateral loading. If the manufacturer specifies that the rail may be installed at a forward inclination angle greater than 1° relative to the vertical, the test is repeated for the maximum forward inclination angle specified by the manufacturer (not exceeding 15°). The test mass must not come into contact with the ground, the distance H_{AD} must not exceed 1 m or the distance H_{LD} must not exceed 0.5 m.

During functionality testing with a laterally inclined rail, the rail is installed with a maximum lateral inclination in accordance with the manufacturer's specifications, but not less than 5° and not more than 15° , with a tolerance of $+2^\circ$ (Fig. 13). The length of the rail is at least 2 m. The quick-release device is connected to the central eyelet of the test mass, while the GTFA's attachment element is connected to the edge eyelet of the test mass. The test mass must correspond to the minimum declared load. The GTFA is positioned on the rail so that the distance between its upper end and the bracket does not exceed 300 mm. If the rail includes openings, teeth, or similar features, the GTFA is positioned directly below one of them, and at a maximum distance of 300 mm below the upper bracket. The test mass is positioned at the maximum height above the GTFA, and at a maximum horizontal distance of 300 mm from the rail, with the GTFA remaining unlocked. The test mass is released without any initial velocity and once the fall is arrested and the test mass is stabilized, the following distances are measured: H_{AD} – the distance between the initial and final positions of the test mass attachment point and H_{LD} – the distance between the initial and final positions of the GTFA. The test is repeated using a test mass corresponding to the maximum declared load, which must not be less than $100^{\pm 1}$ kg. The test mass must not come into contact with the ground, and in both tests the distance H_{AD} must not exceed 1 m or the distance H_{LD} must not exceed 0.5 m.

6. CORROSION RESISTANCE TEST

After all previously described tests, the GTFA with rigid anchor line is subjected to a corrosion resistance test. All metal parts of the GTFA and rigid anchor line is exposed to the neutral salt spray test in accordance with EN ISO 9227, for a period of $24^{+0.05}$ h [17]. They must then be dried for $60^{\pm 5}$ min at $20^{\pm 2}$ °C. This procedure is repeated once more, so the total exposure consists of two periods of 24 hours and two periods of 60 minutes drying. After this, the examination of the test samples is carried out. All metal parts of the GTFA, including the rigid anchor line, must show no evidence of corrosion that would affect their function (e.g., the proper operation of moving elements or the locking function). White scaling or tarnishing is acceptable as long as the function is not impaired.

7. CONCLUSION

Guided-type fall arresters with rigid anchor lines made of rail are essential elements in ensuring safety during work at height. Compliance with the rigorous requirements specified in the EN 353-1 standard guarantees that these systems provide a high level of protection to users. The methodology outlined in this paper, which includes both static and dynamic testing procedures, offers a systematic approach to evaluating the functionality and reliability of guided-type fall arresters with rigid anchor lines made of rail. The developed methodology has been implemented in the Laboratory for Railway Engineering and Structures Testing at the Faculty of Mechanical and Civil Engineering in Kraljevo, University of Kragujevac, Serbia. Through comprehensive testing, including the verification of design elements, material integrity, and performance under load, it is possible to confirm that the equipment complies with the requirements of the standards.

This paper lays the foundation for the development and refinement of these systems, enabling their broader application in high-risk industries. Additionally, this research contributes to the ongoing efforts to improve the quality and safety of personal fall protection equipment, providing insights that may support the global manufacturing and certification of these systems.

Accordingly, in future work, specific results from the testing of guided-type fall arresters with rail-based rigid anchor lines, conducted by the Laboratory for Railway Engineering and Structures Testing at the Faculty of Mechanical and Civil Engineering in Kraljevo, University of Kragujevac, Serbia, and based on the presented methodology, will be presented.

ACKNOWLEDGEMENTS

The authors are grateful to the Ministry of Science, Technological Development and Innovation of the Republic of Serbia for support (contract no. 451-03-137/2025-03/200108).

REFERENCES

- [1] Y. Kang, S. Siddiqui, S. J. Suk, S. Chi, and C. Kim, "Trends of fall accidents in the U.S. construction industry", *Journal of Construction Engineering and Management*, Vol. 143(8), pp. 04017043-1–04017043-7, [https://doi.org/10.1061/\(ASCE\)CO.1943-7862.0001332](https://doi.org/10.1061/(ASCE)CO.1943-7862.0001332), (2017)
- [2] X. S. Dong, A. Fujimoto, K. Ringen, and Y. Men, "Fatal falls among Hispanic construction workers", *Accident Analysis & Prevention*, Vol. 41(5), pp. 1047–1052, <https://doi.org/10.1016/j.aap.2009.06.012>, (2009)
- [3] J. E. Beavers, J. R. Moore, and W. R. Schriver, "Steel erection fatalities in the construction industry", *Journal of Construction Engineering and Management*, Vol. 135(3), pp. 227–234, [https://doi.org/10.1061/\(ASCE\)0733-9364\(2009\)135:3\(227\)](https://doi.org/10.1061/(ASCE)0733-9364(2009)135:3(227)), (2009)
- [4] A.S. Chan, F. K. W. Wong, D. W. M. Chan, M. C. H. Yam, A. W. K. Kwok, E. W. M. Lam, and E. Cheung, "Work at height fatalities in the repair, maintenance, alteration, and addition works", *Journal of Construction Engineering and Management*, Vol. 134(7), pp. 527–535, [https://doi.org/10.1061/\(ASCE\)0733-9364\(2008\)134:7\(527\)](https://doi.org/10.1061/(ASCE)0733-9364(2008)134:7(527)), (2008)
- [5] N. T. Pham, G. Lelikov, and D. Korolchenko, "Improvement of the safety systems for working at heights on transmission towers", *IOP Conf. Ser. Mater. Sci. Eng.*, Vol. 365(4), p. 042054, <https://doi.org/10.1088/1757-899X/365/4/042054>, (2018)
- [6] Personal fall protection equipment – Guided type fall arresters including an anchor line – Part 1: Guided type fall arresters including a rigid anchor line", *Standard SRPS EN 353-1:2018*, (2018)
- [7] C. C. Liang and C. F. Chiang, "A study on biodynamic models of seated human subjects exposed to vertical vibration", *International Journal of Industrial Ergonomics*, Vol. 36(10), pp. 869–890, <https://doi.org/10.1016/j.ergon.2006.06.008>, (2006)
- [8] J. B. Hernández, M. B. Hernández, G.R. Ortega, F. J. S. Ruiz, V. F. Lara, C. A. M. Santos, "Energy dissipating component in fall arrest system", *South Florida Journal of Development*, Vol. 5(12), pp. 01-15, <https://doi.org/10.46932/sfjdv5n12-061>, (2024)
- [9] K. Baszczyński, "Influence of weather conditions on the performance of energy absorbers and guided type fall arresters on a flexible anchorage line during fall arresting", *Safety Science*, Vol. 42(6), pp. 519-536, <https://doi.org/10.1016/j.ssci.2003.08.003>, (2004)
- [10] K. Baszczyński, "The influence of anchor devices on the performance of retractable type fall arresters protecting against falls from a height", *International Journal of Occupational Safety and Ergonomics*, Vol. 12(3), pp. 307-318, <https://doi.org/10.1080/10803548.2006.11076692>, (2015).
- [11] Y. M. Goh, P. E. D. Love, "Adequacy of personal fall arrest energy absorbers in relation to heavy workers", *Safety Science*, Vol. 48(6), pp. 747-754, <https://doi.org/10.1016/j.ssci.2010.02.020>, (2010)
- [12] Y. M. Goh, "Empirical investigation of the average deployment force of personal fall-arrest energy absorbers", *Journal of Construction Engineering and Management*, Vol. 141(1), pp. 04014059-1–04014059-6, [https://doi.org/10.1061/\(ASCE\)CO.1943-7862.0000910](https://doi.org/10.1061/(ASCE)CO.1943-7862.0000910), (2015)
- [13] <https://www.vertiqualsafety.com/en/fall-arresters/fall-arresters-on-rigid-line-en-353-1/twinstop-1>
- [14] Personal protective equipment against falls from a height – Full body harnesses, *Standard SRPS EN 361:2007*, (2007)
- [15] Personal protective equipment against falls from a height – Connectors, *Standard SRPS EN 362:2008*, (2008)
- [16] Personal protective equipment against falls from a height – Test methods, *Standard SRPS EN 364:2007*, (2007)
- [17] Corrosion tests in artificial atmospheres – Salt spray tests, *Standard SRPS EN ISO 9227:2023*, (2023)